

Meta-Modeling With OptiY® - Design Space Visualization for Electromagnetic Applications in CST Studio Suite®

The-Quan Pham
OptiY e.K. Germany

CST European User Group Meeting
19th-21th April 2010 in Darmstadt

Outline

1. Objective

2. Theoretical Basics

- Gaussian Process
- Visualization of the Adaptive Gaussian Process

3. Practical EM Example

- Waveguide Hybrid Junction
- Design Space of Reflection and Transmission

Objective

Design Space Visualization

- Knowledge about the relationship:
 - **Design Parameters – Product Characteristics**
- Reliability, Safety and Quality Engineering
- Reduce development, manufacturing cost and failure
- Increasing lifetime
- Reduce service after sale

Current Solutions

- Full Factorial Design (Parameter Sweep)
 - n design parameters with k tunable values
 - n^k number of model calculations required
 - High computing effort
 - **Infeasible** for large model (one run takes some hours)
- Other Methods for Design of Experiment (DOE)
 - Less number of model calculations
 - **Inaccurate**

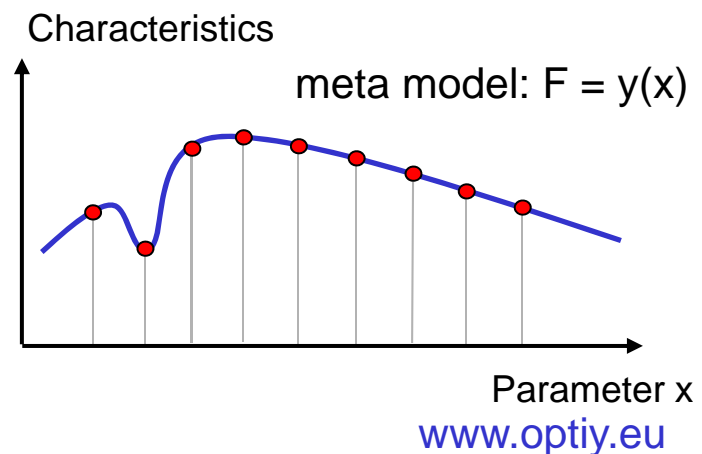
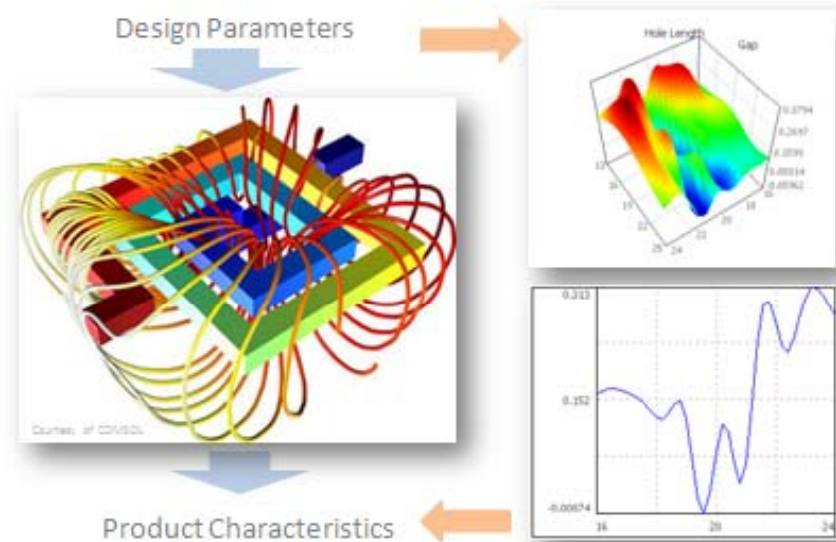

Gaussian Process

- Polynomial $f(\mathbf{x})$ of p^{th} order for global adaptation
- Stochastic process $Z(\mathbf{x})$ for local adaptation

$$\begin{aligned}
 Y(\mathbf{x}) = & f_0 + b_{11}x_1 + b_{12}x_1^2 + \dots + b_{1p}x_1^p \\
 & + b_{21}x_2 + b_{22}x_2^2 + \dots + b_{2p}x_2^p \\
 & \dots \\
 & + b_{n1}x_n + b_{n2}x_n^2 + \dots + b_{np}x_n^p \\
 & + Z(\mathbf{x})
 \end{aligned}$$

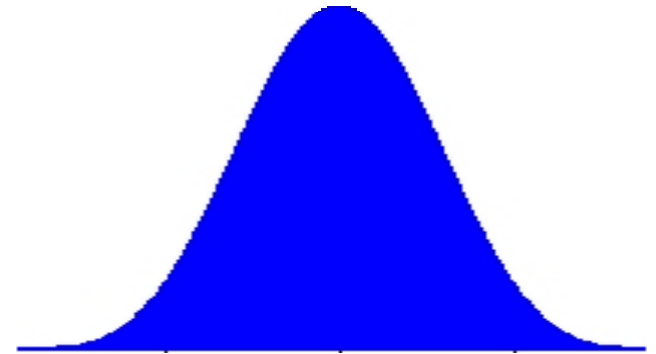

Correlation Function $R(\mathbf{x})$

- Multivariate Gaussian distribution (normal distribution)
- Interpolation between calculated points
- Interactions between individual parameters

$$R(x_i, x_j) = \sum_{k=1}^n w_k^2 (x_i - x_j)^2$$

Visualization of the Adaptive Gaussian Process

$$Y = (X - 5)^2 - 15 \cdot e^{-(X - 1.5)^2} + 5$$

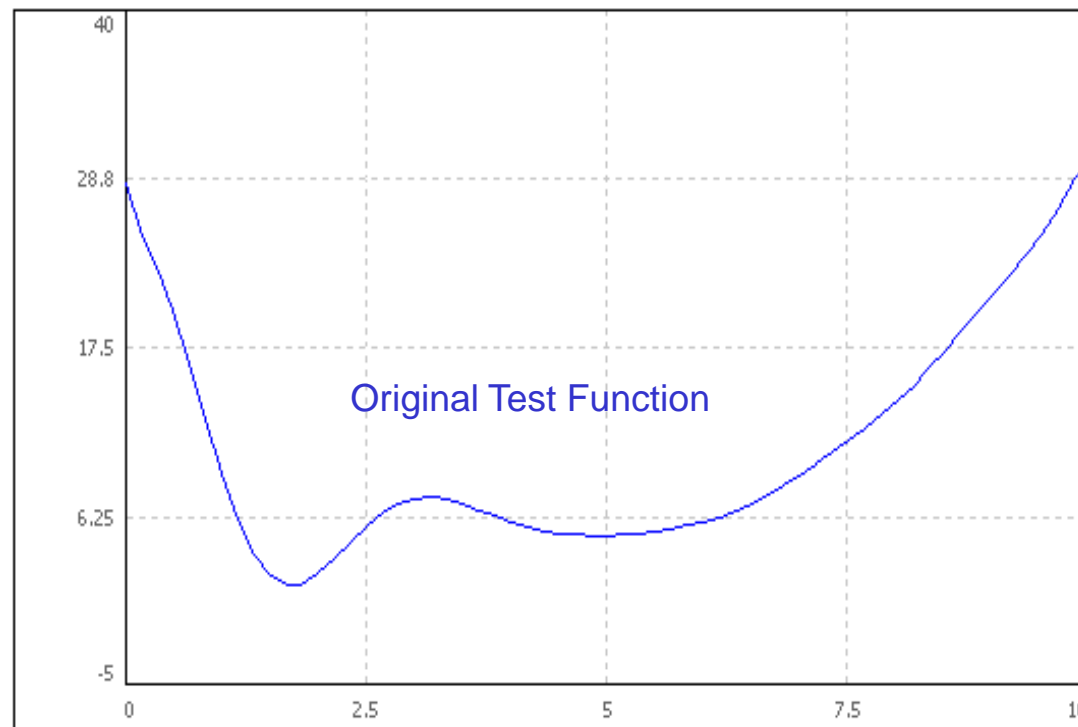

Approximation Loops

Start: 6 Sampling Points

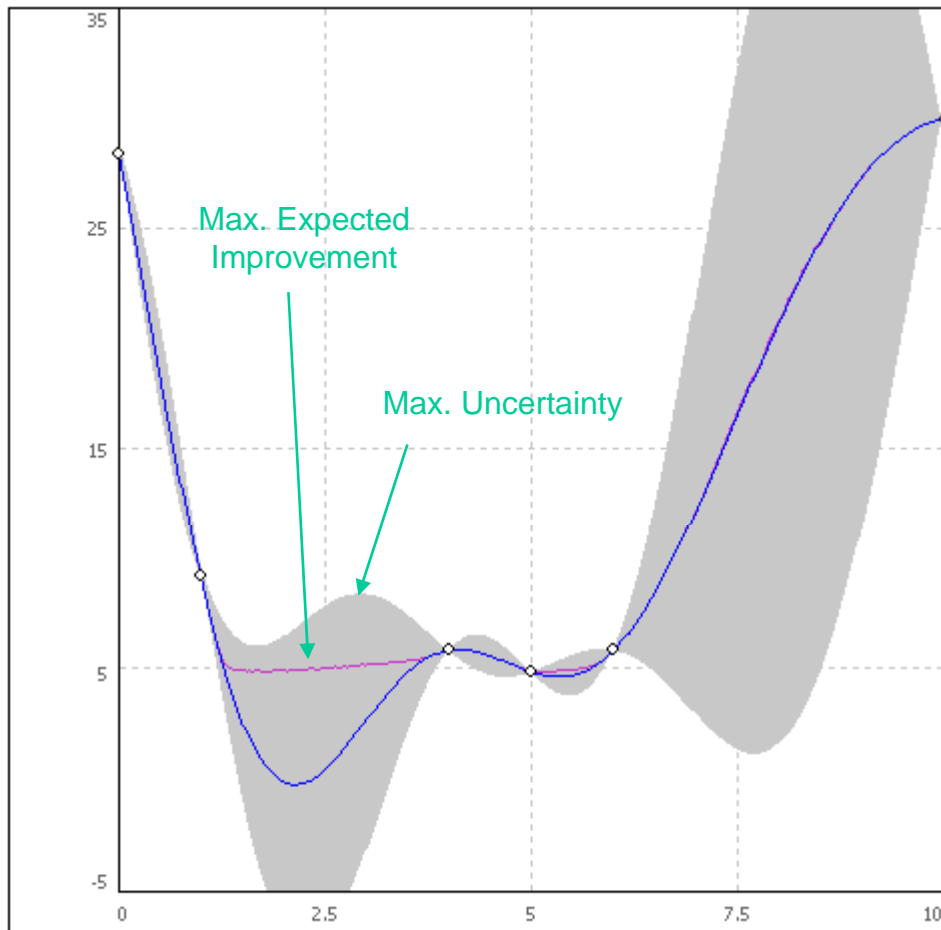

Loop 1

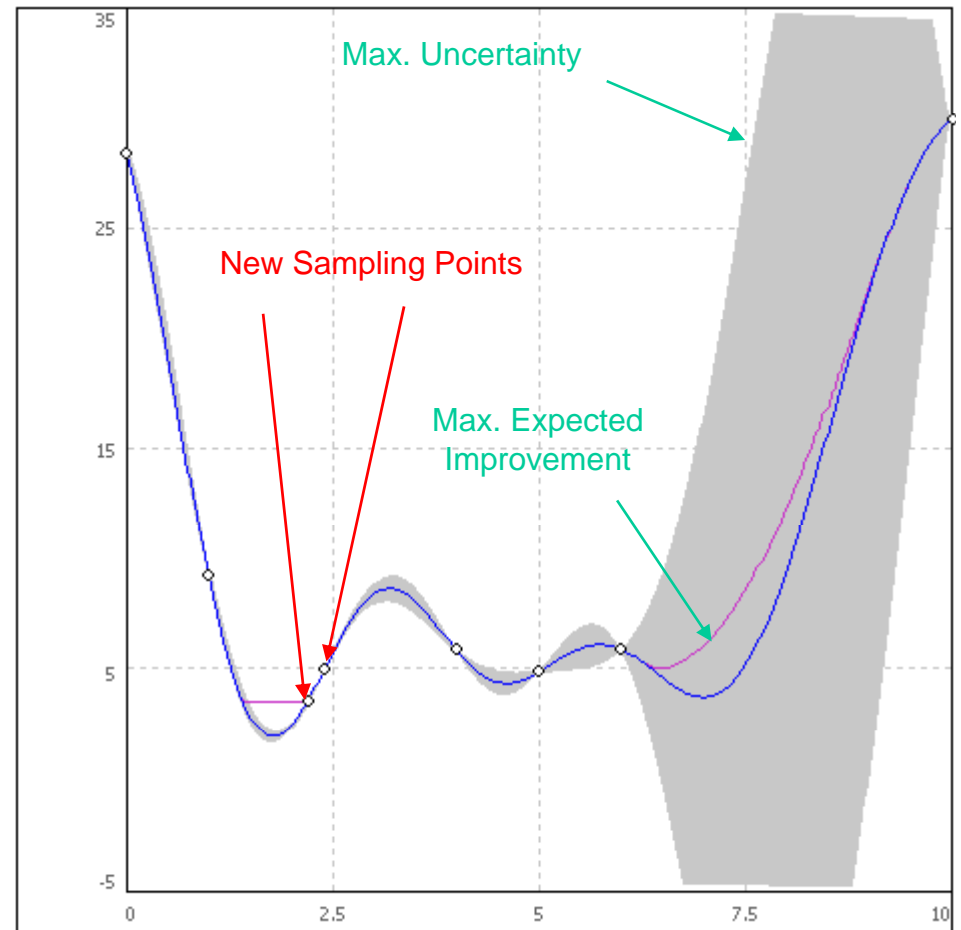

Approximation Loops

Required number of model calculations depends on:

- Number of design parameters
- Degree of response nonlinearity
- Correlation between design parameters

Loop 2

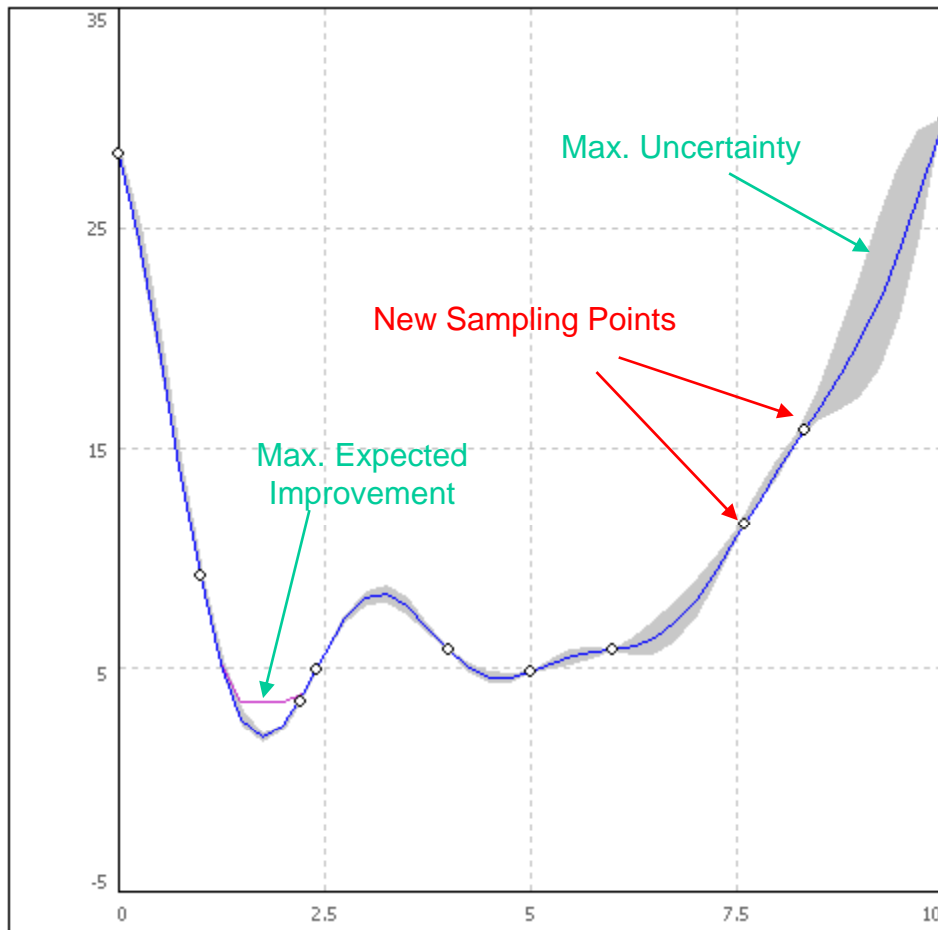

Loop 3: Automatic Stop

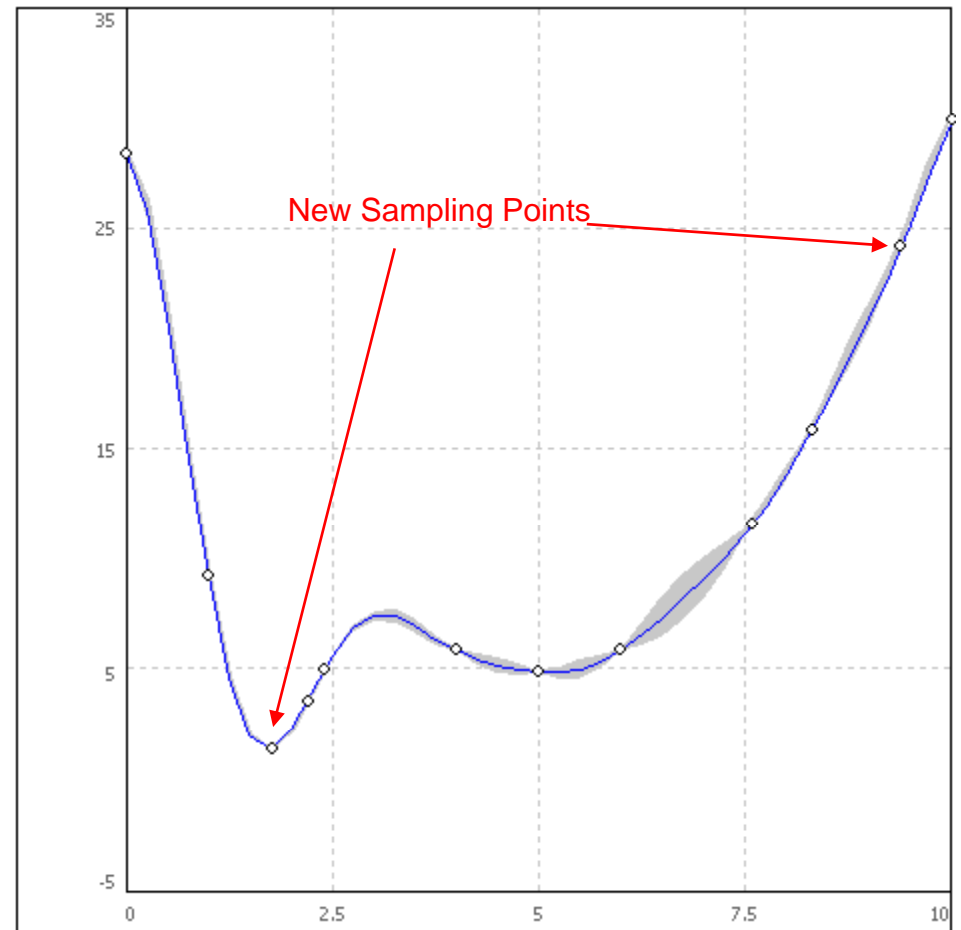

Waveguide Hybrid Junction

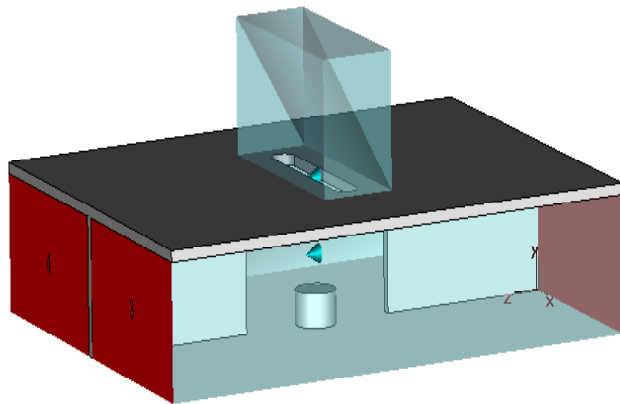

Design Space

Hole Length 16 – 24 mm
 Hole Width 2.4 – 3.6 mm
 Gap 13 – 25 mm
 Disk High 1.8 – 4.2 mm
 Disk Radius 1.9 – 3.1 mm

Product Characteristics:

Transmission and Reflection at the operating point 8 GHz based on transient simulation in CST Studio Suite

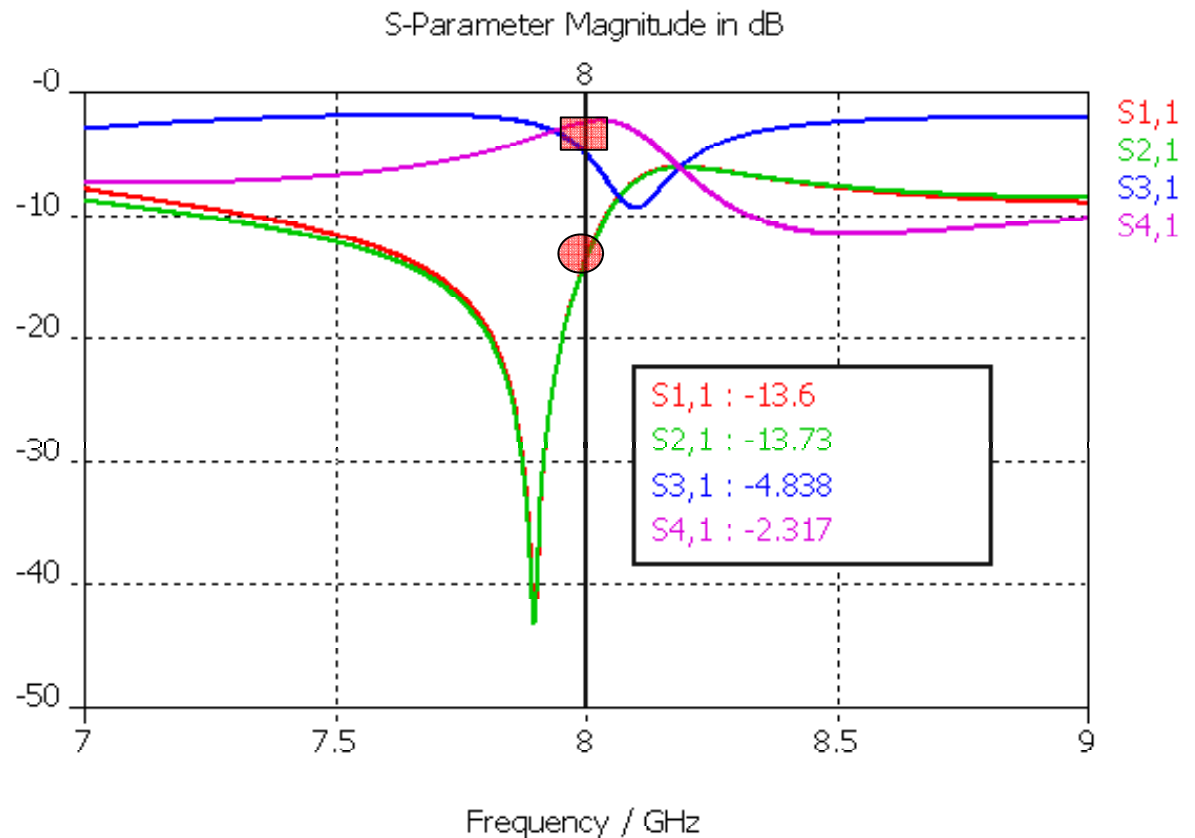

Design Space Visualization: 2D Section Diagrams

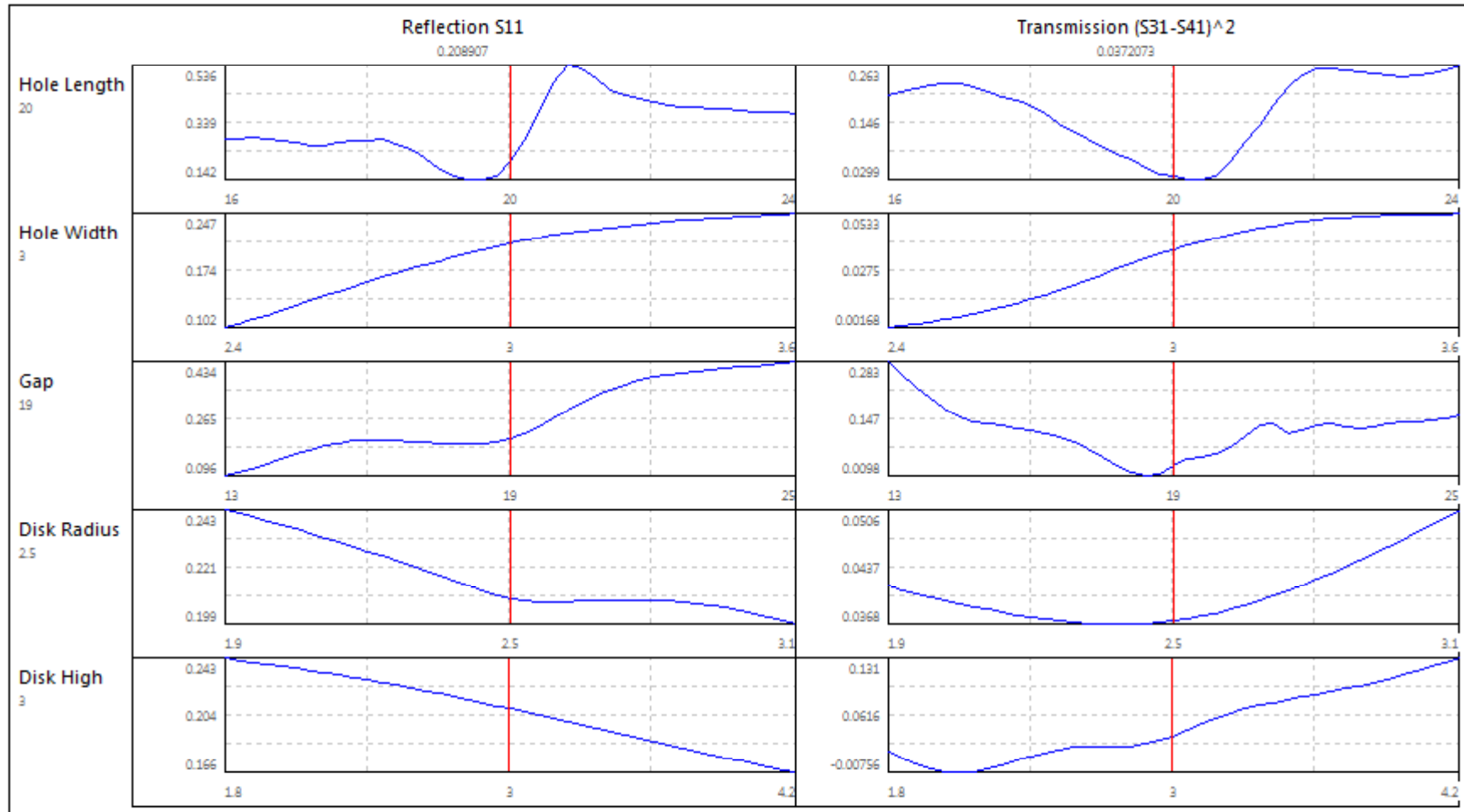

Design Space Visualization: 3D Graphics

Reflection

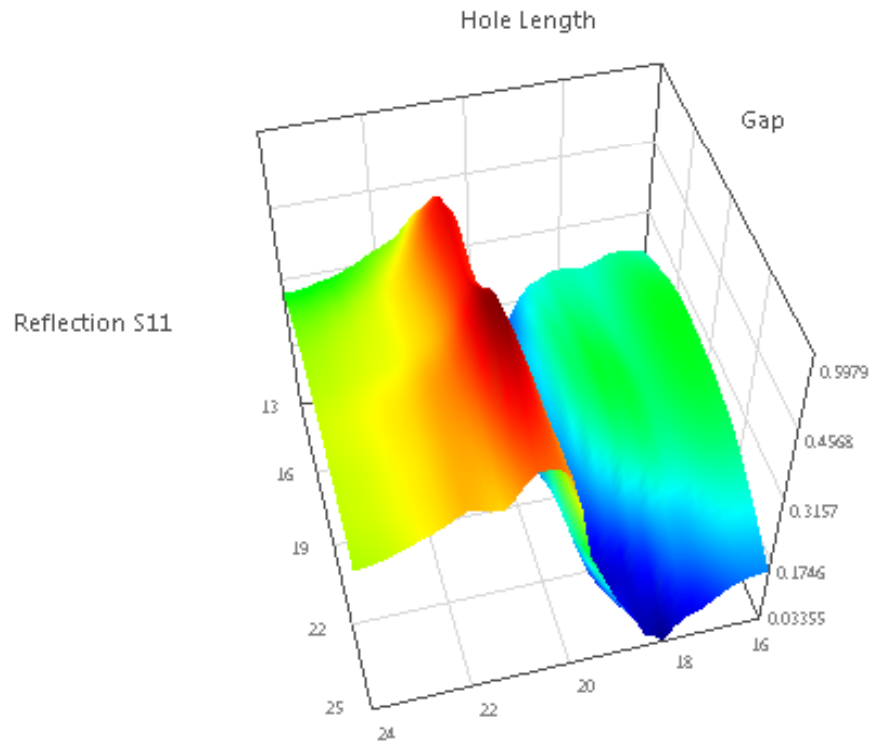

Transmission Difference

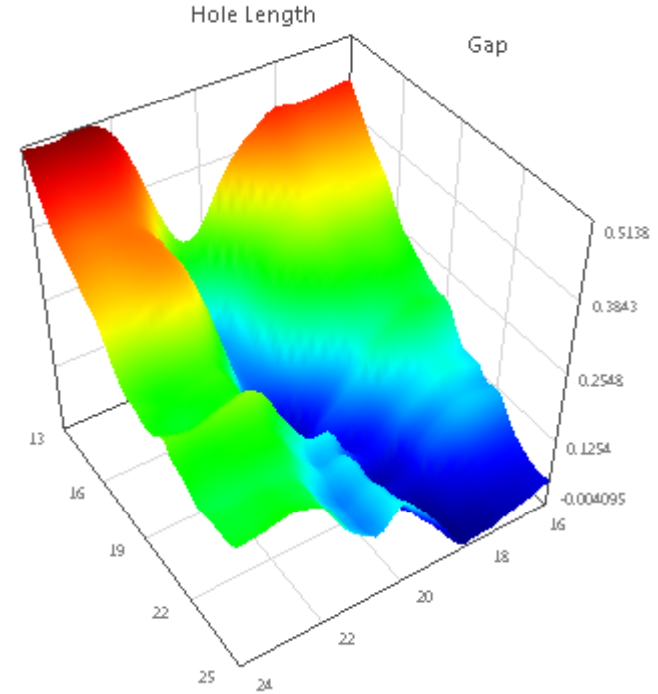

Global Nonlinear and Quantitative Sensitivity Analysis

Design Parameter Importance

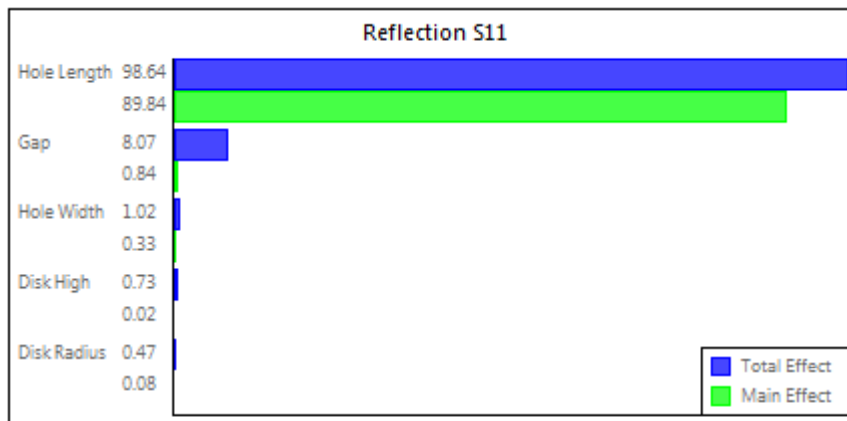

Design Parameter Interactions

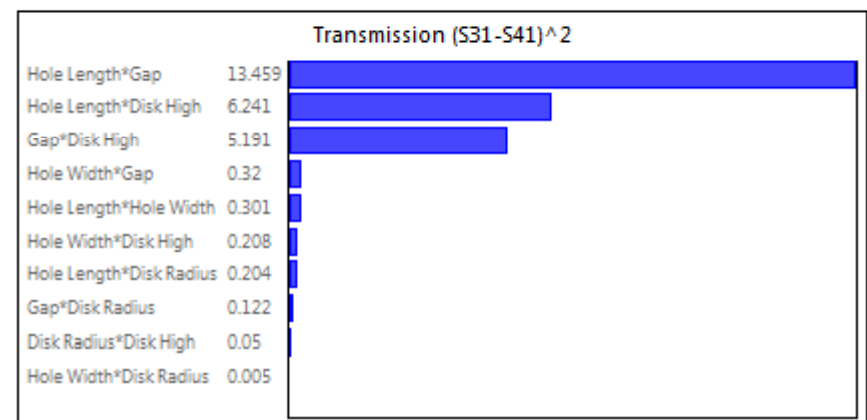
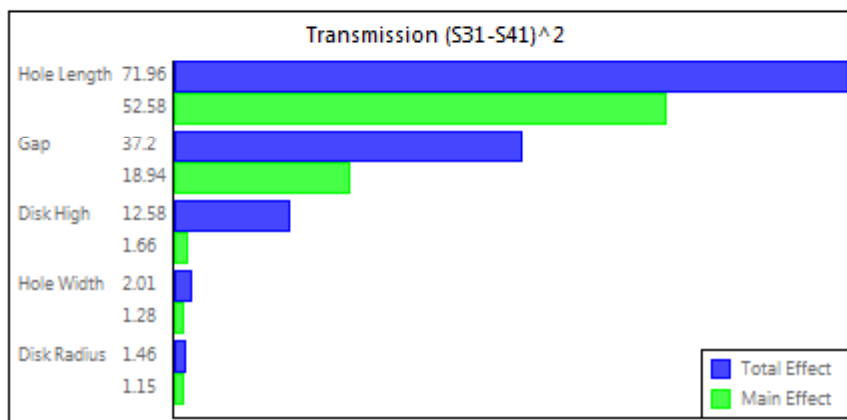
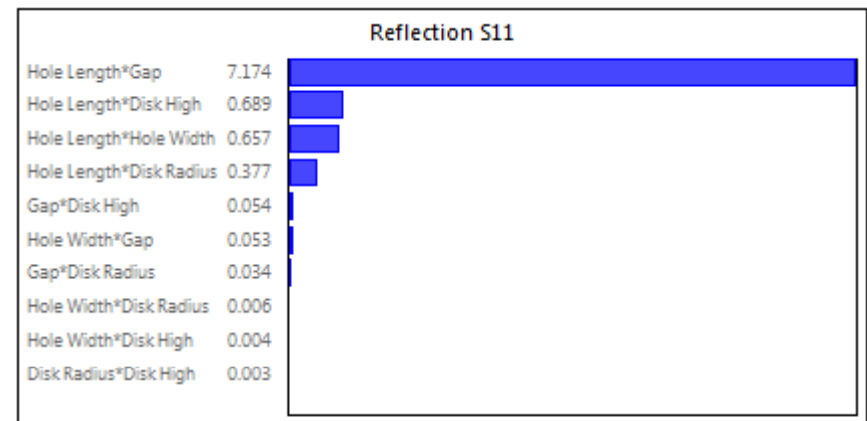

Probabilistic Simulation (Yield Analysis)

Design Optimization

Design goal: minimize the reflection S11 to get the optimal design point in the design space (Table: optimal design parameters with manufacturing tolerances)

Design Robustness

Tolerances of design parameters cause variability of the reflection and transmission: quality and reliability in series manufacturing

Name	Values	Local Tolerance	Unit
Hole Length	19.75	0.2	mm
Hole Width	2.4	0.2	mm
Gap	19	0.2	mm
Disk Radius	2.47	0.2	mm
Disk High	4.2	0.2	mm

Input Distributions

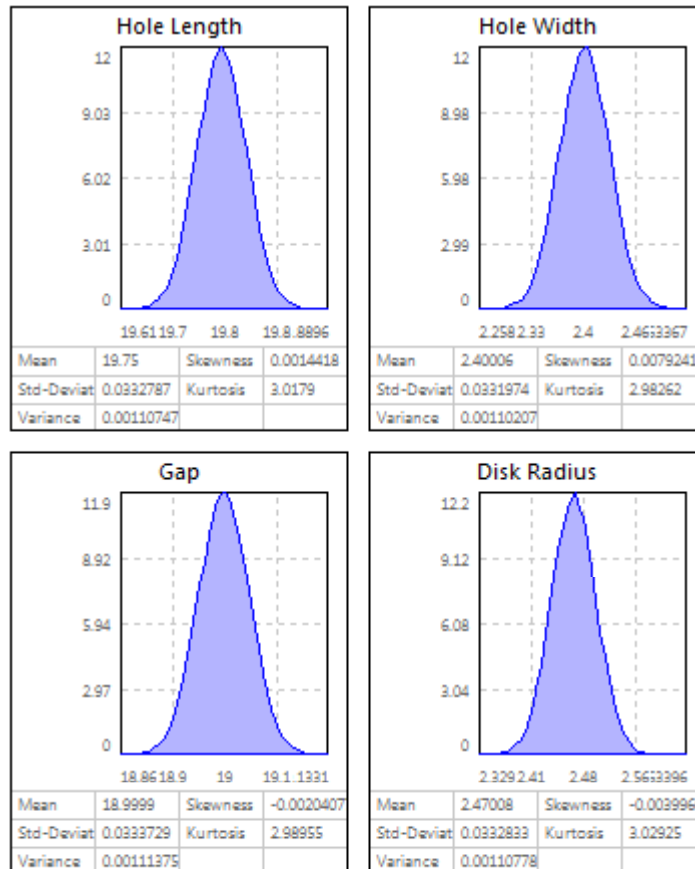

Output Distributions

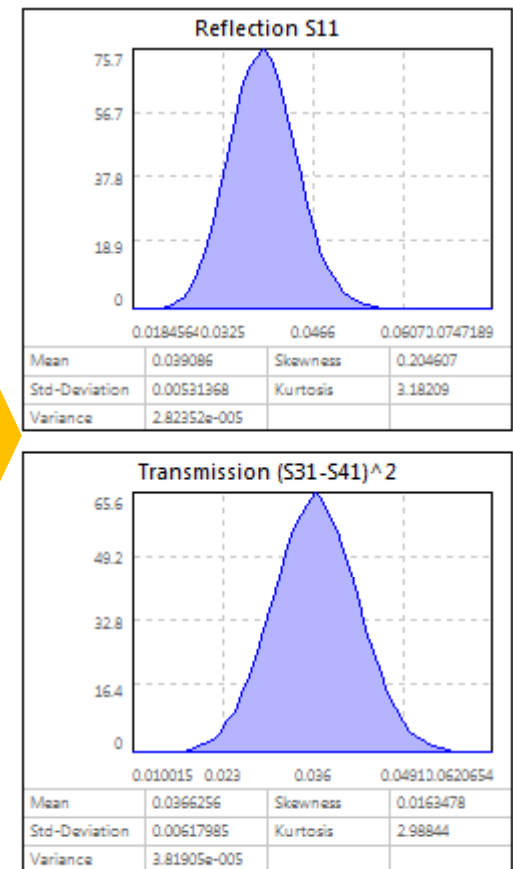

Robust Design Optimization

- Taguchi Quality Loss Function:
 $L = \text{Cost} * (\text{Variance} + (\text{Mean} - \text{Target Value})^2)$
- Quality loss of Transmission S31,S41
 Target Value = 0 (e.g. S31 = S41), Cost = 1

Nominal Design

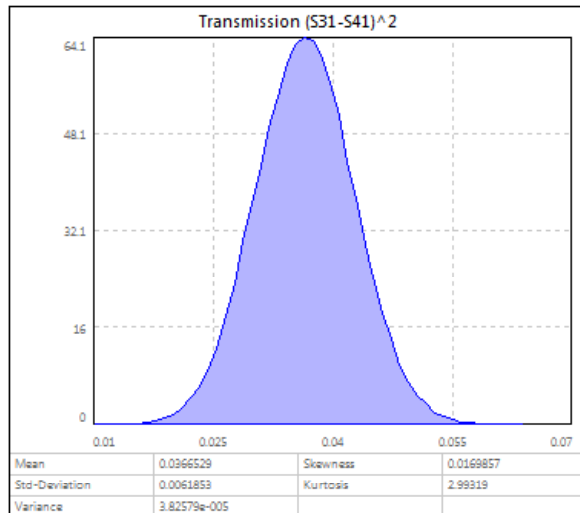

Robust Design

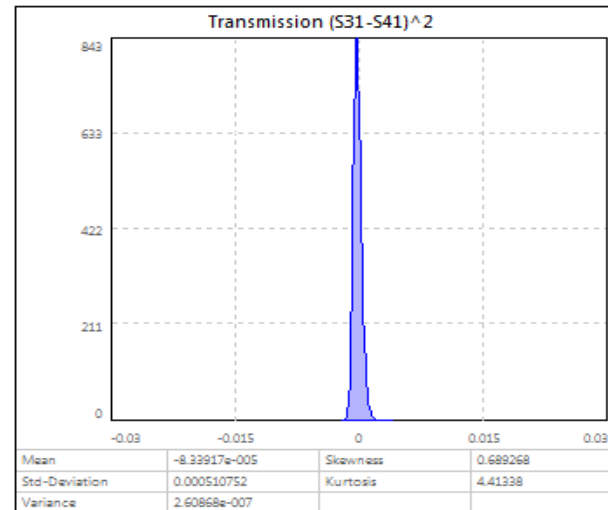

Minimizing the quality loss function for the transmission

- Nominal Design
 $L = 1.3E-3$
- Robust Design
 $L = 2.6 E-7$

Name	Values	Local Tolerance	U	C
Hole Length	19.75	0.2		F
Hole Width	2.4	0.2		F
Gap	19	0.2		G
Disk Radius	2.47	0.2		D
Disk High	4.2	0.2		D

Name	Values	Local Tolerance	U	C
Hole Length	18.6992372	0.2		H
Hole Width	2.60716168	0.2		H
Gap	24.1586773	0.2		G
Disk Radius	2.25980617	0.2		D
Disk High	2.05806809	0.2		D

Code-Export of Surrogate Model for System Simulation

- Automatic Code-Export in C, Modelica or Matlab
- Fast surrogate model for total system simulation (e.g. Matlab/Simulink, Circuit-Simulator)
- Development of controller or circuit in case of co-simulation with electromagnetic applications

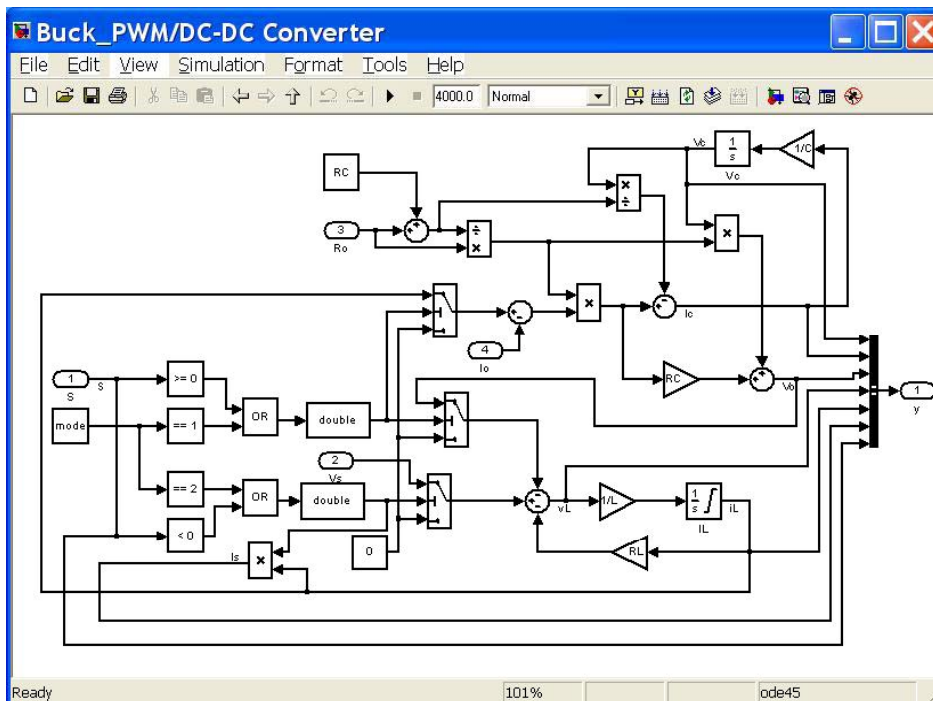

```

double F(double i, double s)
{
    double p[2];
    double x1[2];
    double x2[2];
    double y = -45.7372055;
    y = y+10.5254853*pow(i,1);
    y = y+4.52081477*pow(s,1);
    p[0] = 0.151298213;
    p[1] = 0.928373134;
    x1[0] = i;
    x1[1] = s;
    x2[0] = 5.01;
    x2[1] = 2.02;
    y = y-183.986579*Covariance(x1,x2,p);
    x2[0] = 0.01;
    x2[1] = 0.02;
    y = y-8524.5598*Covariance(x1,x2,p);
    x2[0] = 2.01;
    x2[1] = 0.02;
    y = y+27577.7253*Covariance(x1,x2,p);
    :
    :
    x2[0] = 10.01;
    x2[1] = 4.02;
    y = y-1042.30105*Covariance(x1,x2,p);
    return y;
}
    
```

Conclusion

- Meta-Modeling is a process to win the mathematical relationship between design parameters and product characteristics based on the adaptive response surface methodology.
- The number of required model calculations is less. Therefore, it is applicable for large product models with running time of hours.
- The meta-model can be used for improvement of the design under real conditions related to quality and reliability. It can be also exported to surrogate model in the case of system simulation
- We apply on the waveguide hybrid junction in CST Studio Suite. The robust design process has been demonstrated