



# Analysis of the RF Emission from Differential Busses

Stef Worm

Philips Applied Technologies / EMC  
[www.emc.philips.com](http://www.emc.philips.com)

CST User Group Meeting 2007



# Motivation

- Modern interconnect requires increasingly higher speeds
- Most signal integrity issues are solved by differential signaling
- But, EMI is still a problem in practice
  
- Project = Investigate RF emission from differential busses:
  - Develop methodology
  - Perform parameter studies

# Analysis Method

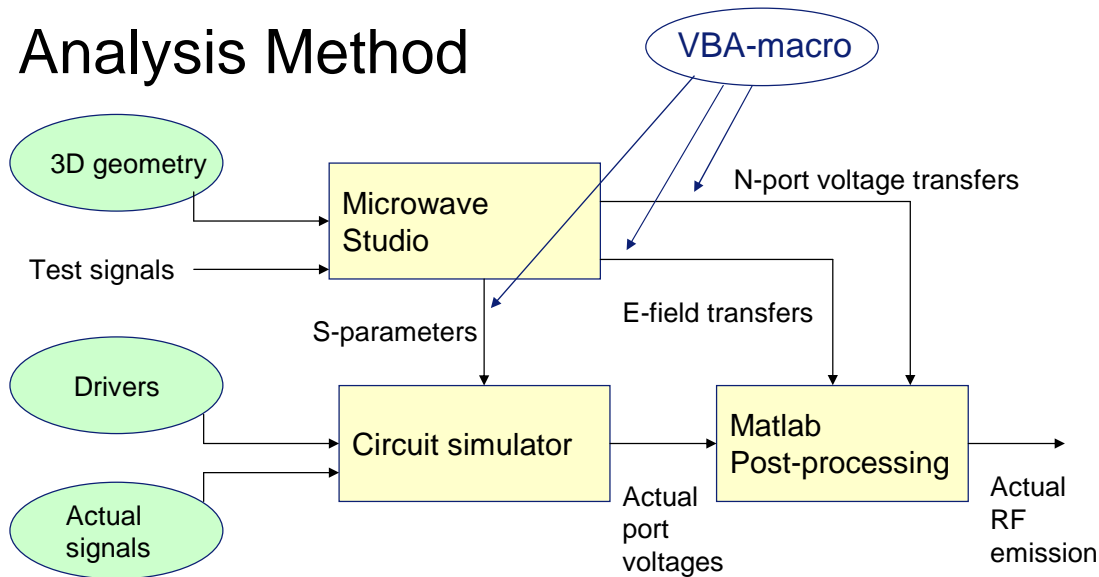

- Characterize the 3D geometry once (port voltages, S-parameters and farfield  $E(\theta, \phi)$  in  $15^\circ$  steps)
- Calculate port voltages for the actual signals
- Determine RF emission (repeat for different signals)

# Basic Steps

- Define the 3D geometry
- Define S-parameter sources and lumped elements
- Define farfield monitors
- Calculate port voltages and farfield on a sphere with 10 m radius and  $15^\circ$  steps  $(\theta, \phi)$  for each excitation
- Save port voltages, S-parameters and farfield data (macro)
- Calculate the actual port voltages using the S-parameters with the actual sources and terminations (circuit simulation)
- Express the actual port voltages as a linear combination of the port voltages found in the 3D simulation
- Calculate the actual far field with the same linear combination

# Parameterized Geometry Definitions

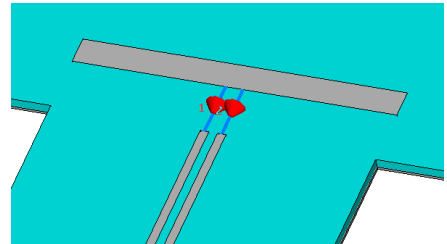
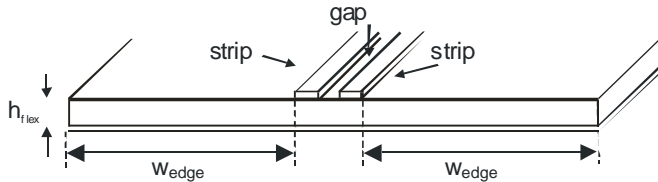
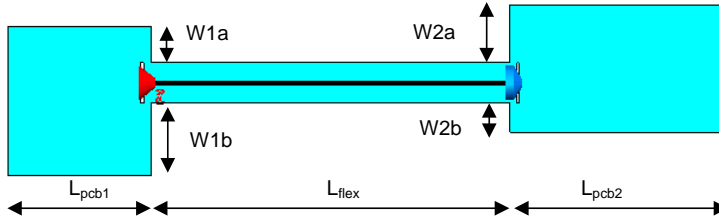

Vary length, edge width and size of PCBs

# Effect of Length and Ground Edge

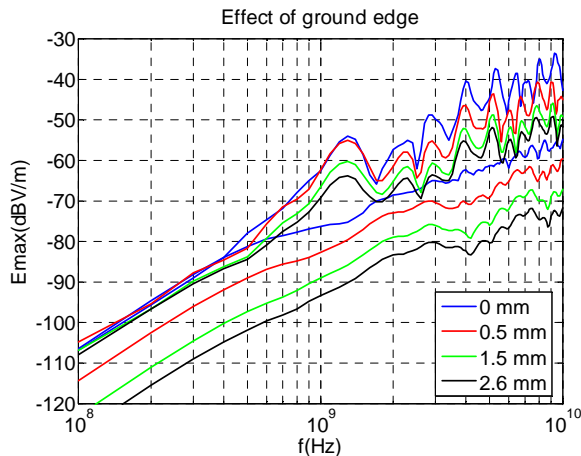
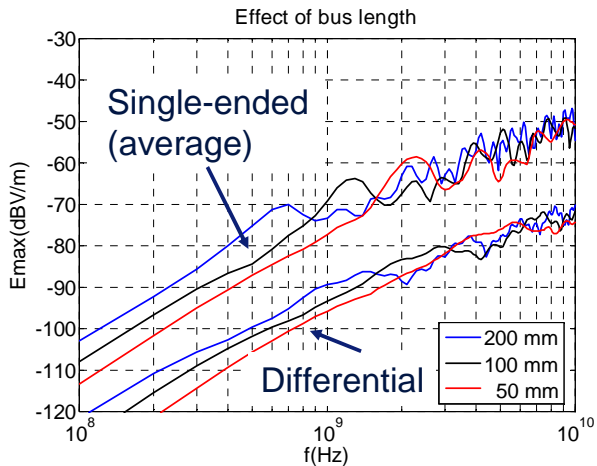

1 V single ended compared to two times 1 V DM  
 Maximum emission level at 10 m (free space)  
 DM emission is not negligible

# Effect of Attached PCBs

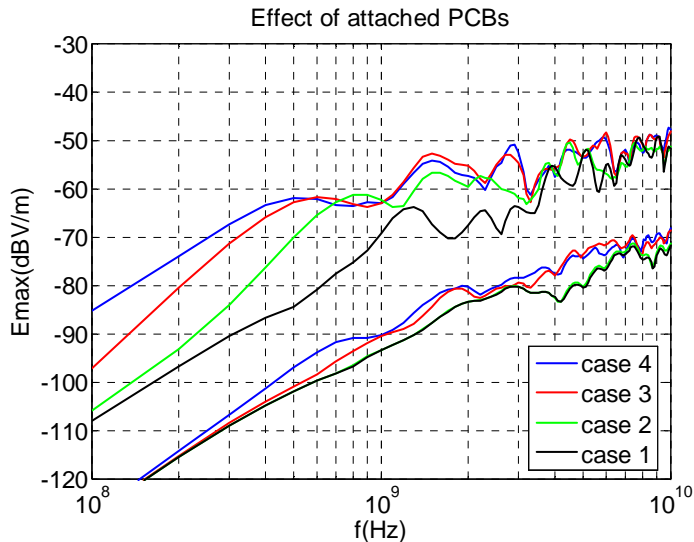
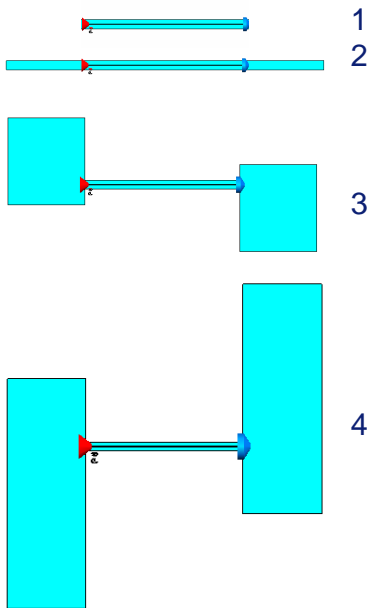

DM emission is less sensitive to attached PCBs

# Signal with Unequal Rise - Fall Times

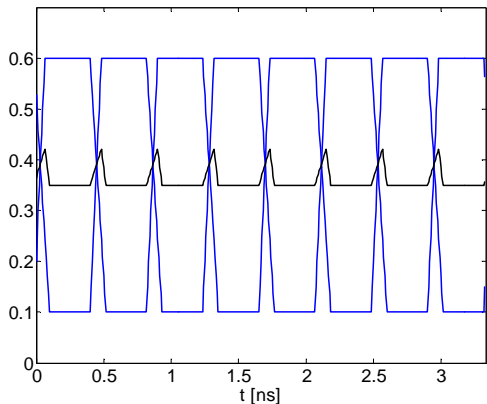

Two complementary clock signals 1200 MHz (PCI-Express)  
Asymmetry in rise and fall time causes common mode pulses  
Example  $\tau_{\text{rise}}$  83 ps,  $\tau_{\text{fall}}$  117 ps

# Toggle Signal vs. Random Data

DM

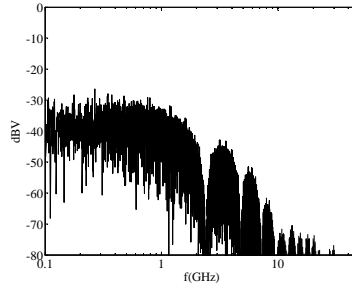
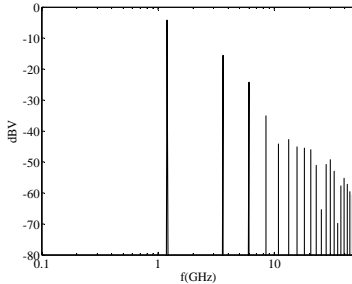

CM

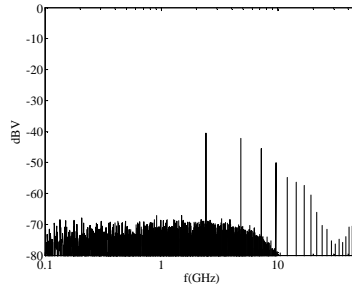
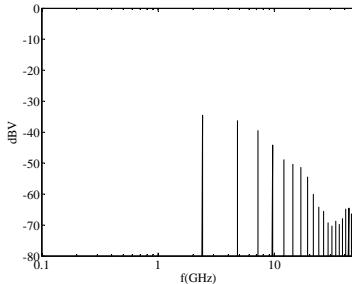

DM and CM spectra occur at separate frequencies ( $\tau_{\text{rise}} < \tau_{\text{fall}}$ )  
 Discrete lines in random data spectrum

# EMI Due to Unequal Rise - Fall Times

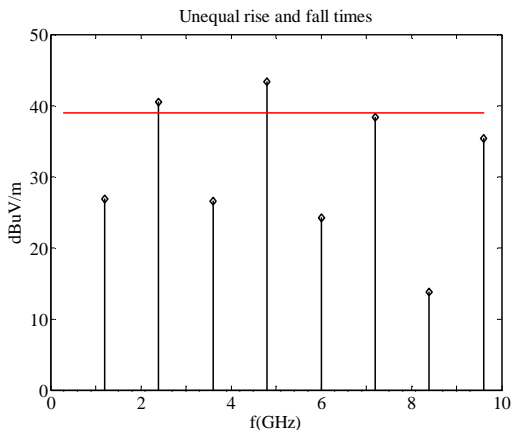

Toggle signal 1200 MHz,  $\tau_{\text{rise}}$  83 ps,  $\tau_{\text{fall}}$  117 ps

Bus length 100 mm, edge 20H, 2 PCBs attached

CM (20 mV rms) yields more emission than DM (830 mV rms)

# Long LVDS Bus

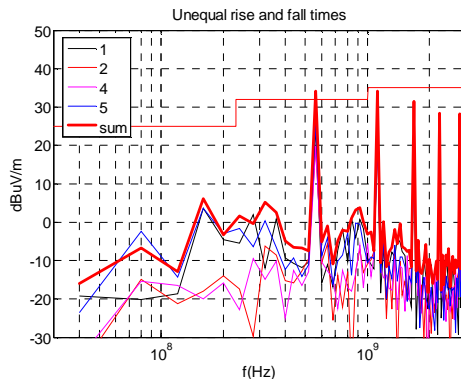
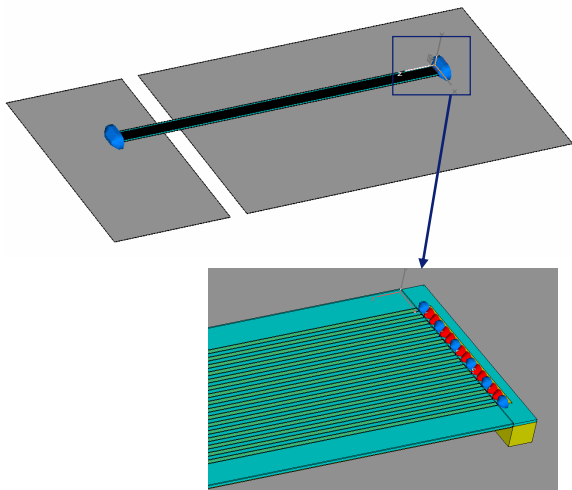

- 5 differential pairs, 6 ground tracks, 1 ground layer
- Flex foil length 1 m, total length 1.4 m
- Minimum mesh 0.5 mm yields 1.8M mesh cells
- Simulation shows which lanes to assign to clock and data

# Summary

- Specifications for differential busses often claim to be “intended for low EMI”.
- In practice still a lot of problems occur.
  
- We developed a methodology to combine circuit models with 3D models for RF emission simulations.
- Both signals and geometry are important for EMI.
- Parameter studies were performed on signals and geometry.
- Useful design guidelines were generated.