

EM/Circuit Co-simulation

Vratislav Sokol



Agenda

- Motivation for EM/Circuit Co-simulation
- Standard versus **Transient** Co-simulation
- Standard Co-simulation examples
 - Filter tuning
 - Antenna Array
- Transient Co-simulation examples
 - Peak detector
 - SRD generator
 - UWB balanced amplifier
- Conclusion



New feature
in v.2009

Motivation

- Speeding up the design process
- Avoiding Brute-Force optimization approach
- Including all layout discontinuities, housing effects, mutual coupling of the circuit element
- Including complex equivalent circuits and/or nonlinear components
- Antenna matching networks, excitation of beam-forming antenna arrays
- Exploiting of geometry symmetries of the structure - splitting up the 3D model
- Space-Mapping technique
- Quick tolerance/yield analysis without need of 3D EM simulation
- System level simulation



Standard versus Transient Co-simulation

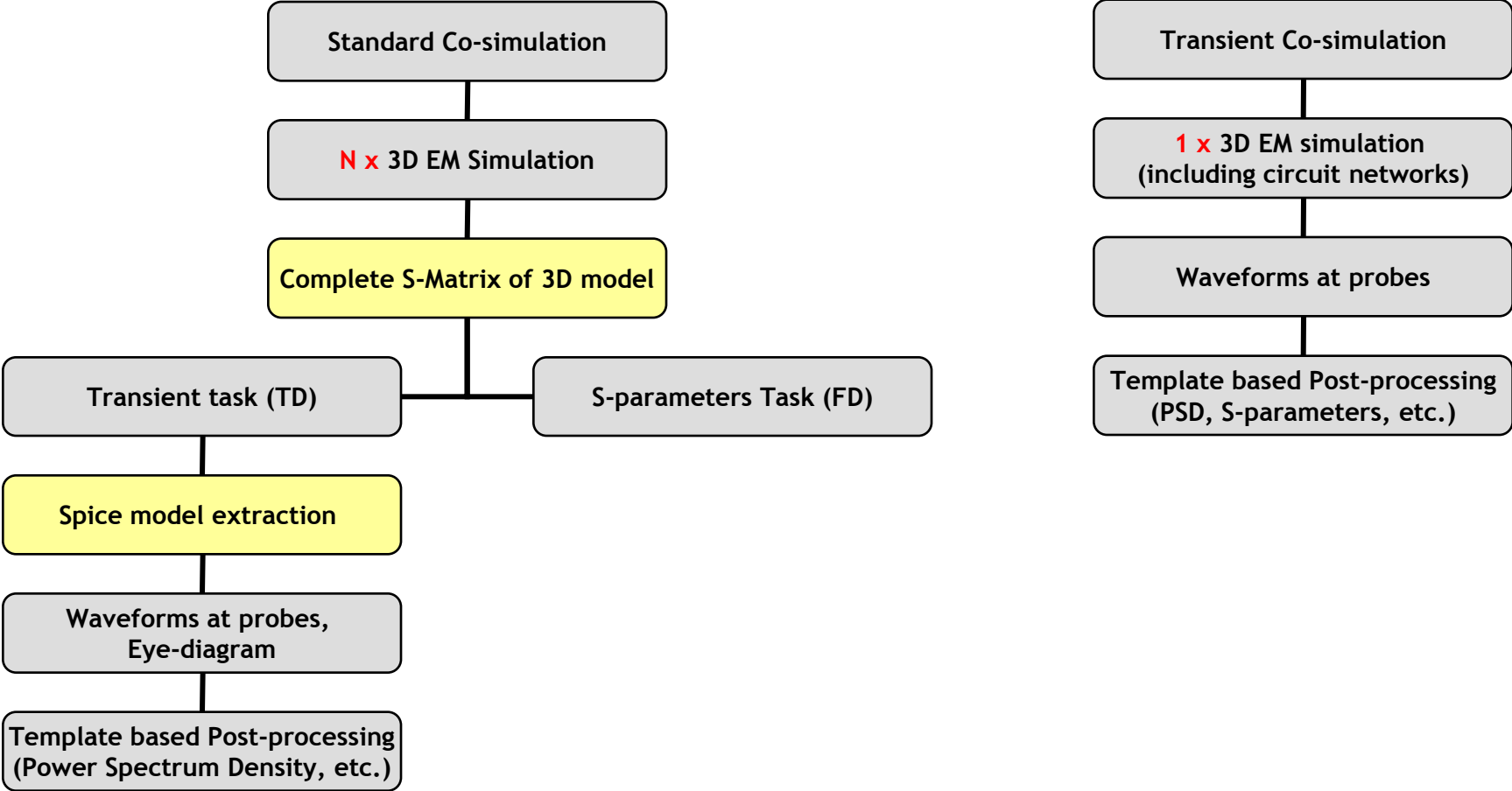

Agenda

- Motivation for EM/Circuit Co-simulation
- Standard versus Transient Co-simulation
- **Standard Co-simulation examples**
 - Filter tuning
 - Antenna Array
- **Transient Co-simulation examples**
 - Peak detector
 - SRD generator
 - UWB balanced amplifier
- **Conclusion**



Example 1: Filter Tuning

(Standard Co-simulation)

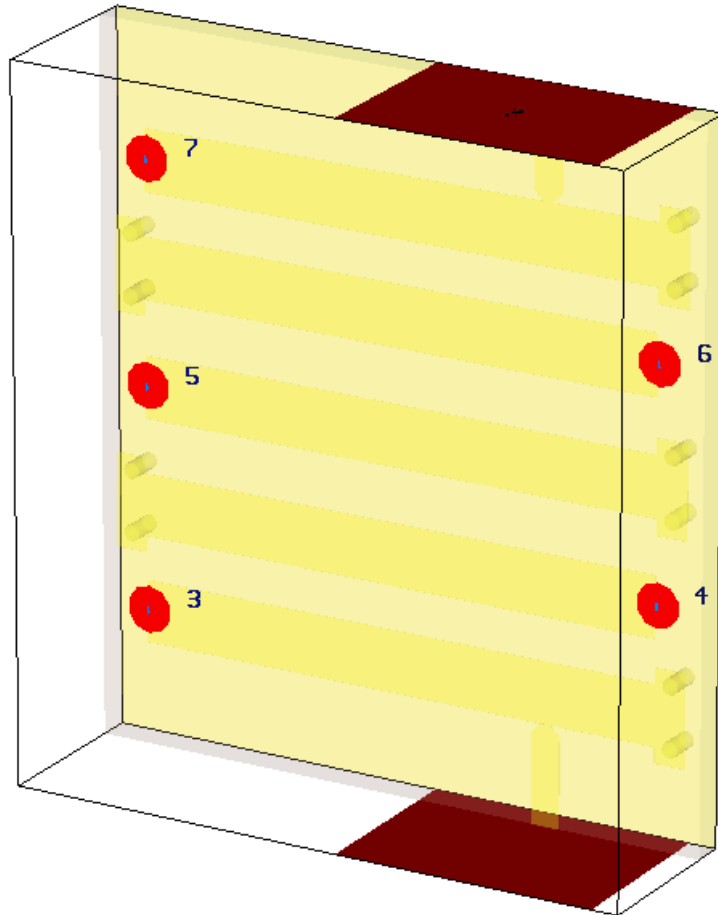

Spacing between resonators
(S_{12} , S_{23} , S_{34} , S_{45})

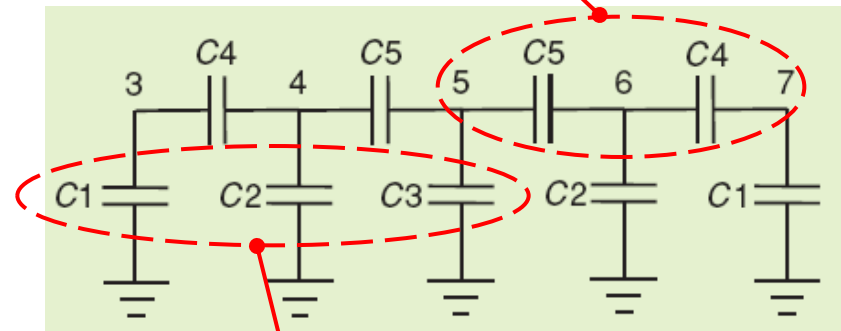

Length of resonators (L_1 - L_5)

Implementation in Design Studio

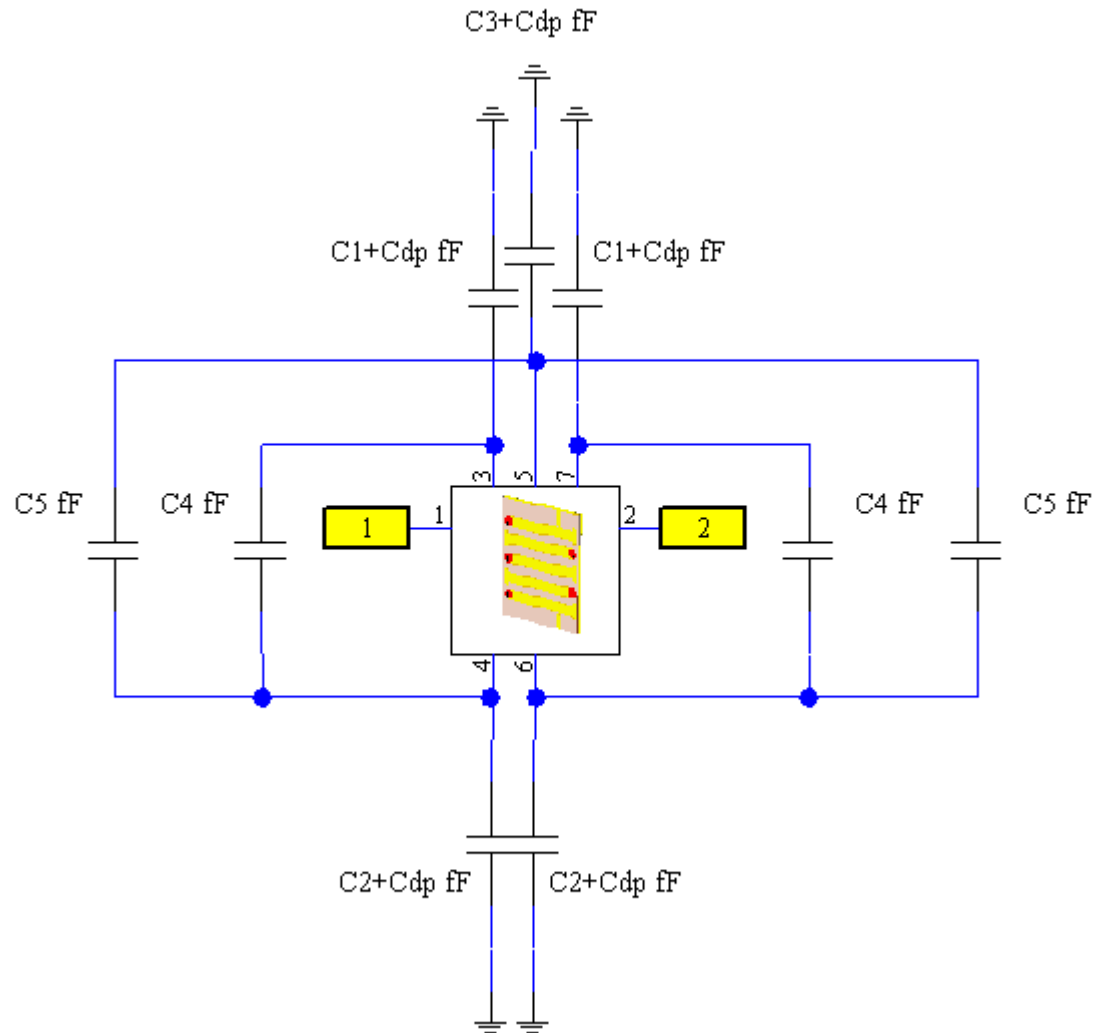

Optimization Result

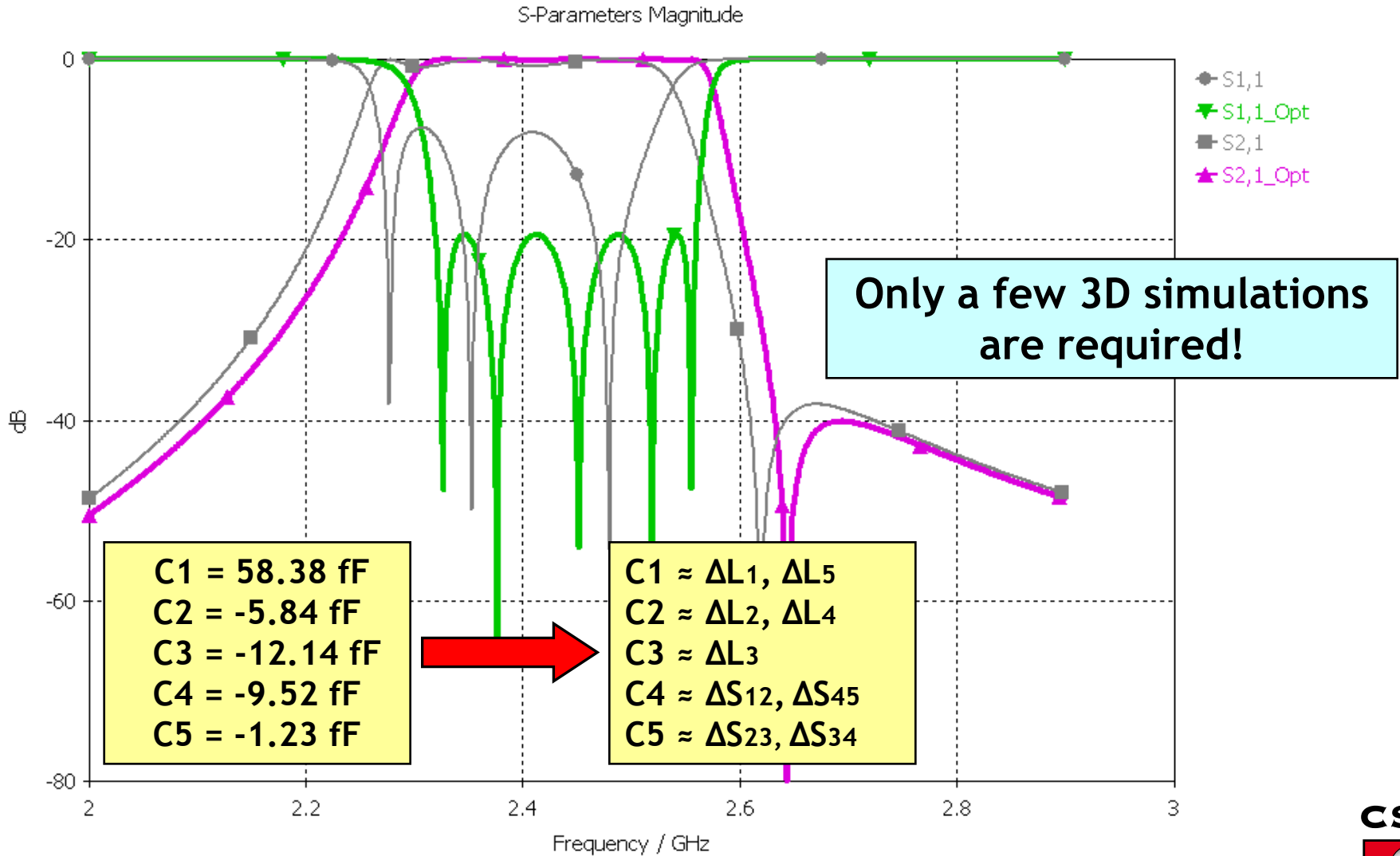

Example 2: Feeding Network + Antenna Array (Standard Co-simulation)

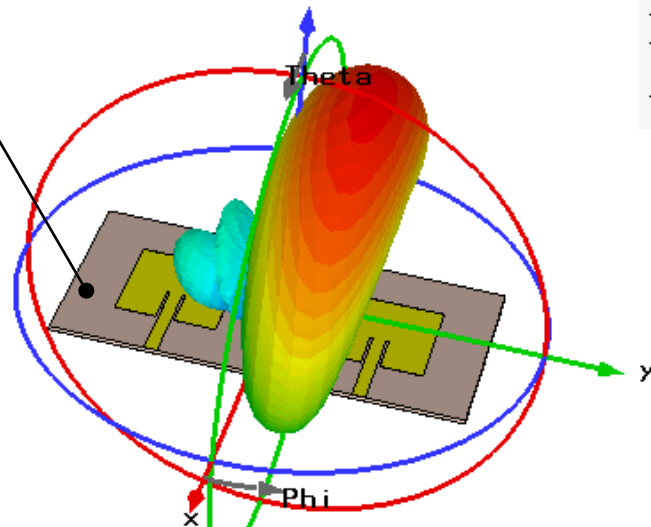
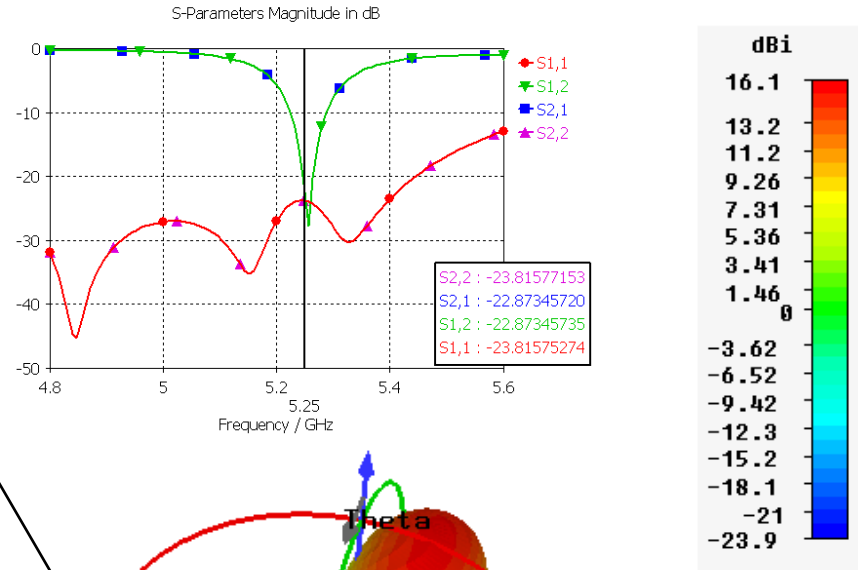
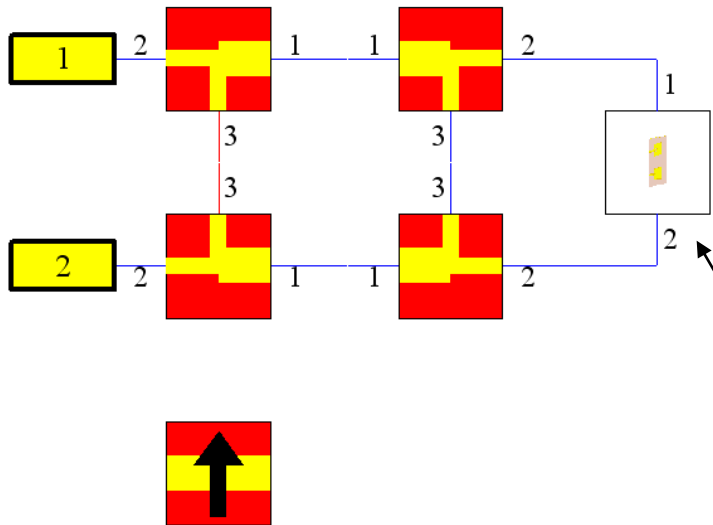

Type	Farfield (Array)
Approximation	enabled ($kR \gg 1$)
Monitor	Farfield (f=5.25) [S-Parameters1]
Component	Abs
Output	Directivity
Frequency	5.25
Rad. effic.	-0.2988 dB
Tot. effic.	-0.3507 dB
System [S-Parameters1]:	
Rad. effic.	-0.2970 dB
Tot. effic.	-0.3374 dB
Dir.	16.09 dBi

3D model in MWS fed with DS circuit network

S-Parameters Task: Combine Results

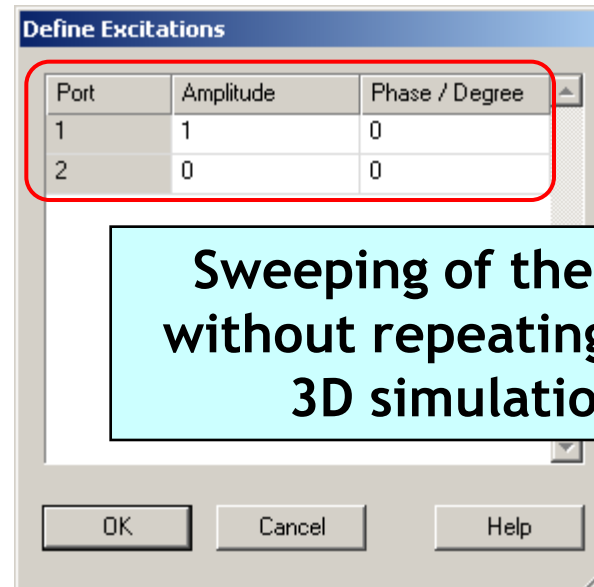
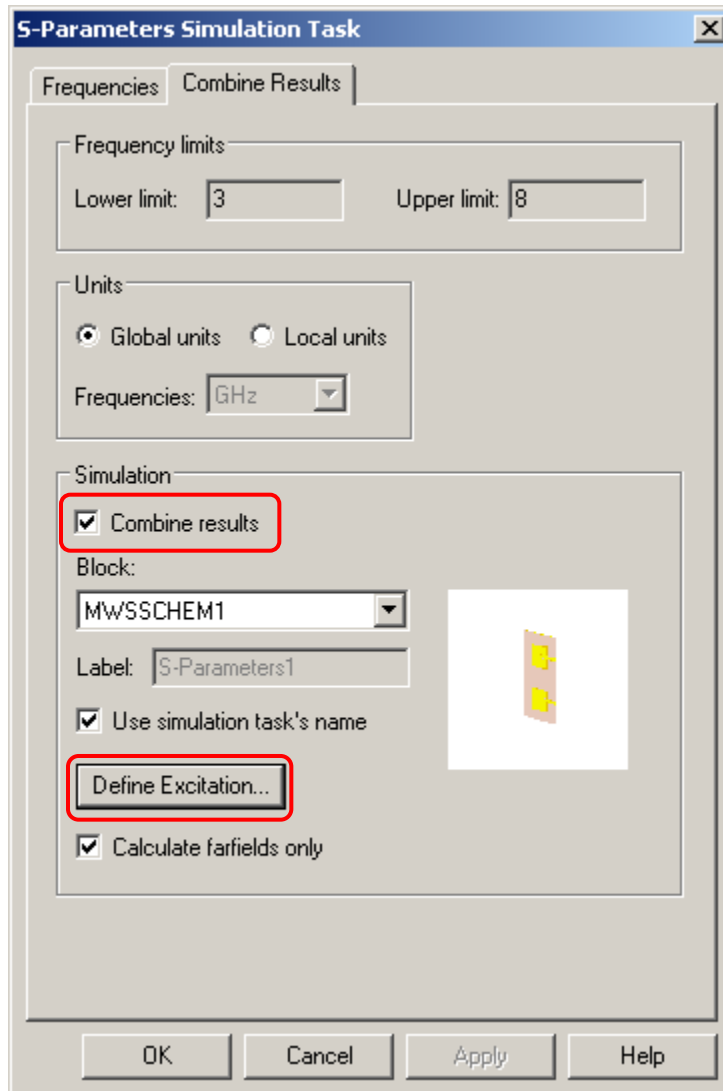

Type	Farfield (Array)
Approximation	enabled (kR >> 1)
Monitor	farfield (f=5.25) [S-Parameters1]
Component	Abs
Output	Directivity
Frequency	5.25
Rad. effic.	-0.2988 dB
Tot. effic.	-0.3507 dB
System [S-Parameters1]:	
Rad. effic.	-0.2970 dB
Tot. effic.	-0.3374 dB
Dir.	16.09 dBi

Agenda

- Motivation for EM/Circuit Co-simulation
- Standard versus Transient Co-simulation
- Standard Co-simulation examples
 - Filter tuning
 - Antenna Array
- **Transient Co-simulation examples**
 - Peak detector
 - SRD generator
 - UWB balanced amplifier
- **Conclusion**

Example 3: Peak Detector (Transient Co-simulation)

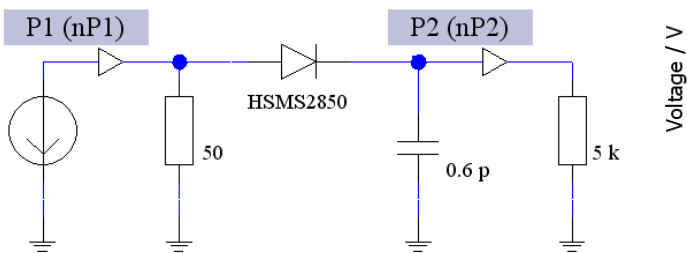
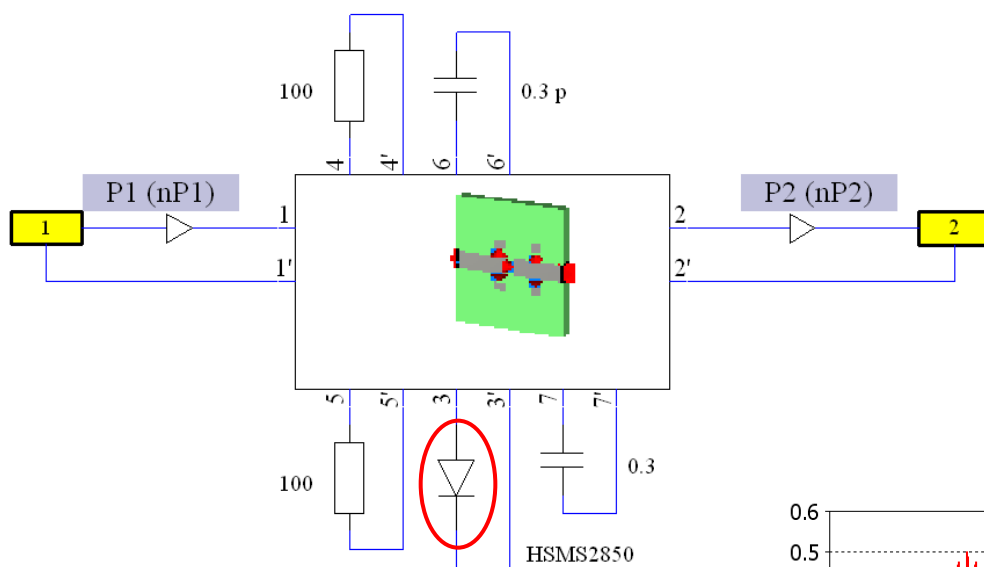

Voltage / V

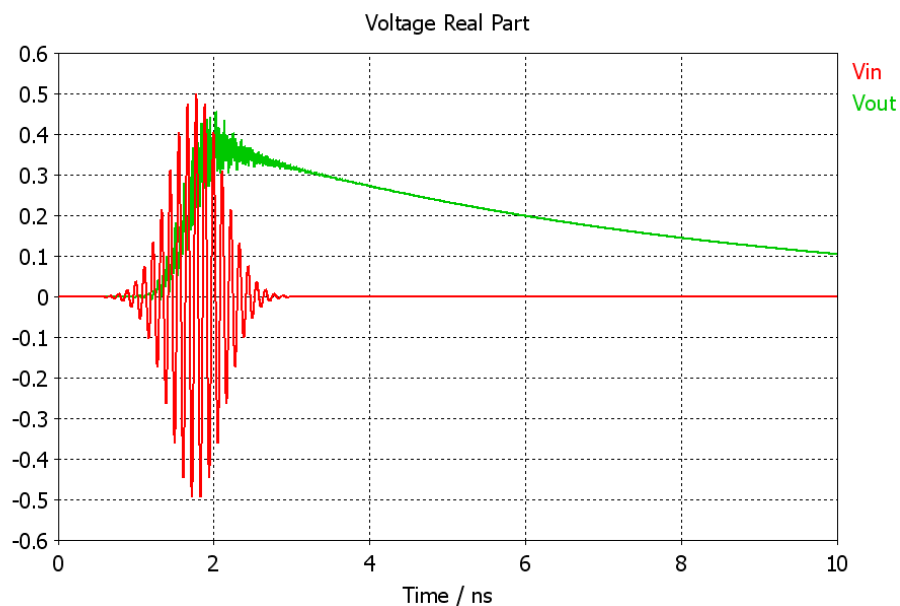

Transient task: MWS co-simulation

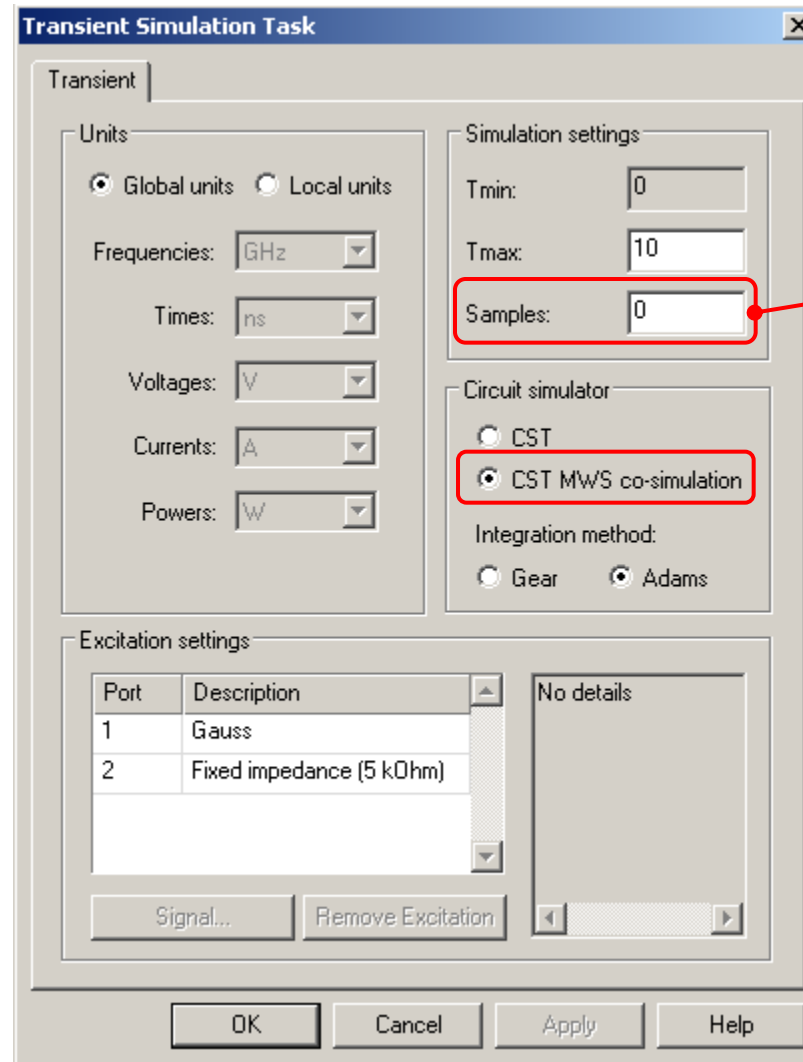
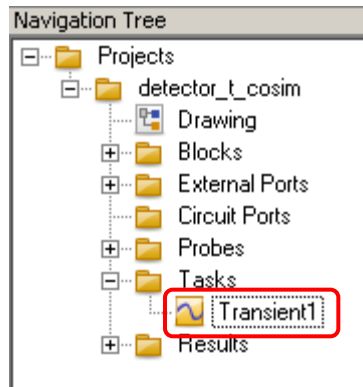

“0” means
adaptive
sampling

Example 4: SRD Pulse Generator I.

(Transient Co-simulation)

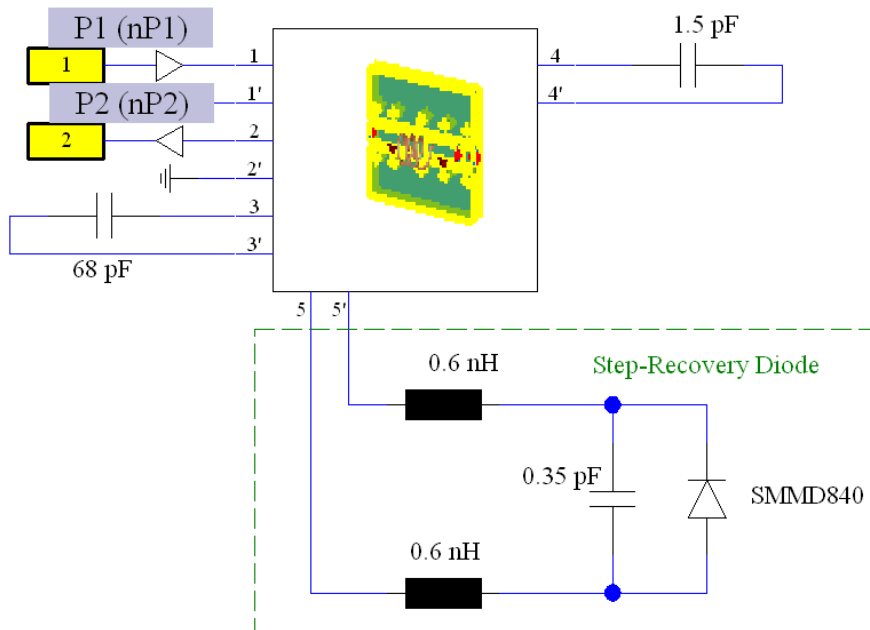
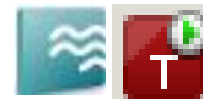

DS canvas:

- circuit elements
- transient task with „MWS Co-simulation“
- probes

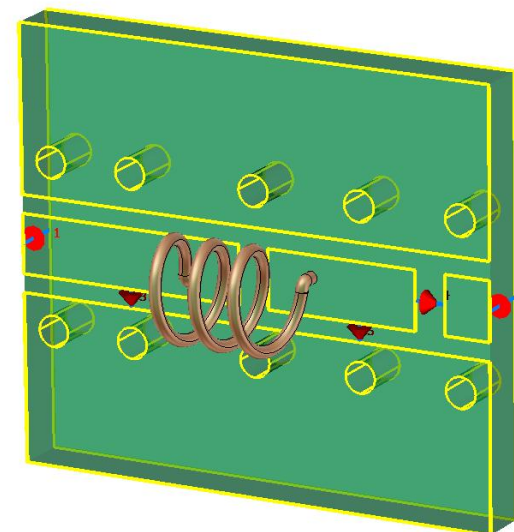

MWS model

Example 4: SRD Pulse Generator II.

(Transient Co-simulation)

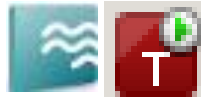

Waveforms

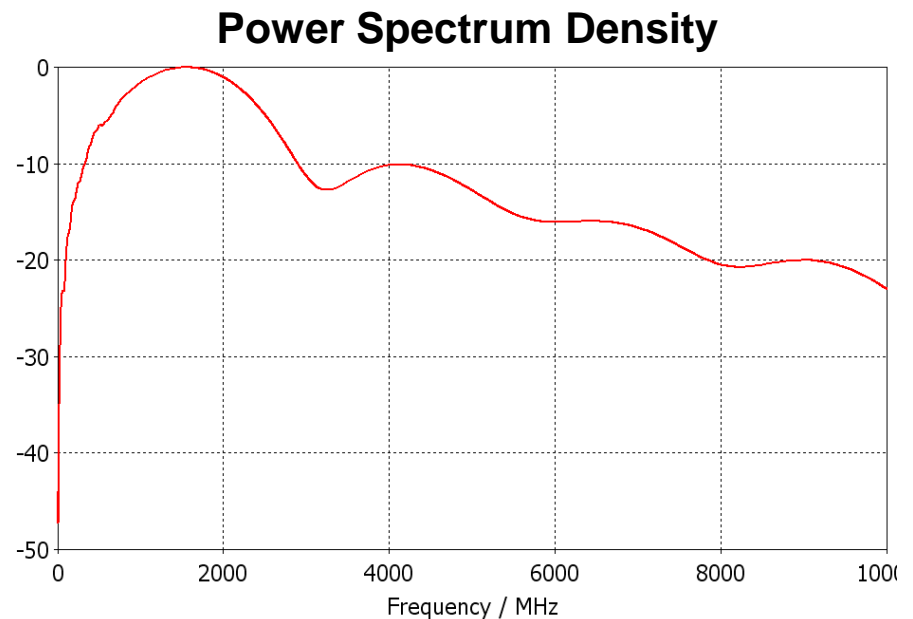
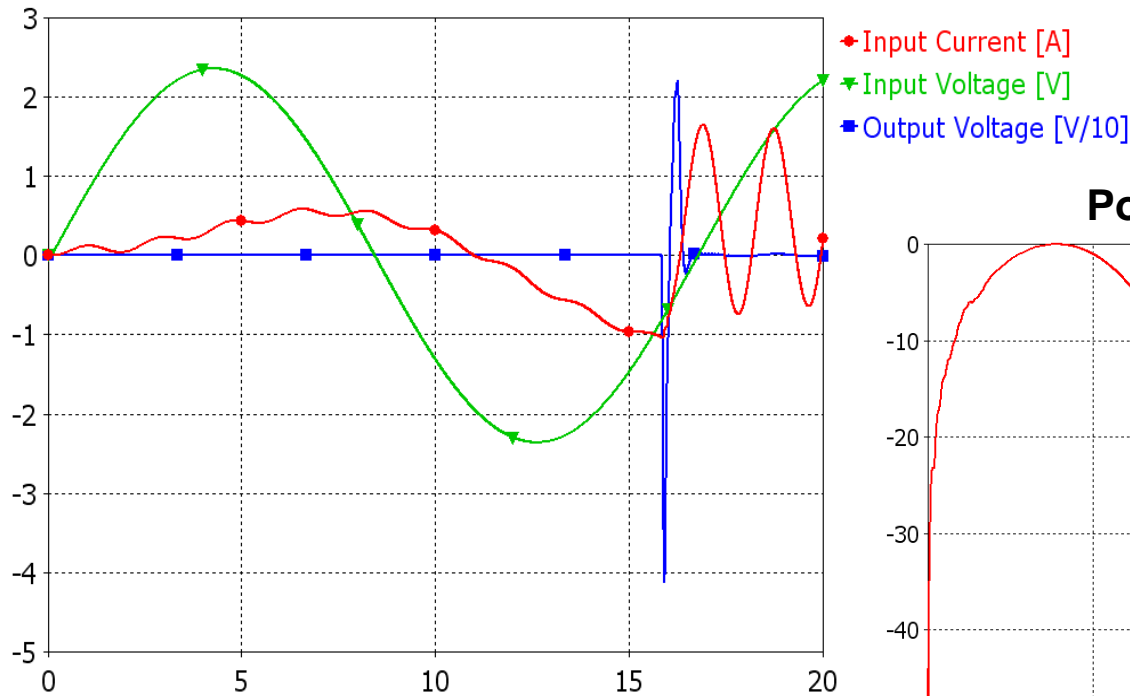

In order to obtain correct results using any frequency domain approach, more than **300 harmonics** would need to be taken into account!



Example 5: UWB Balanced Amplifier I.

(Standard Co-simulation)

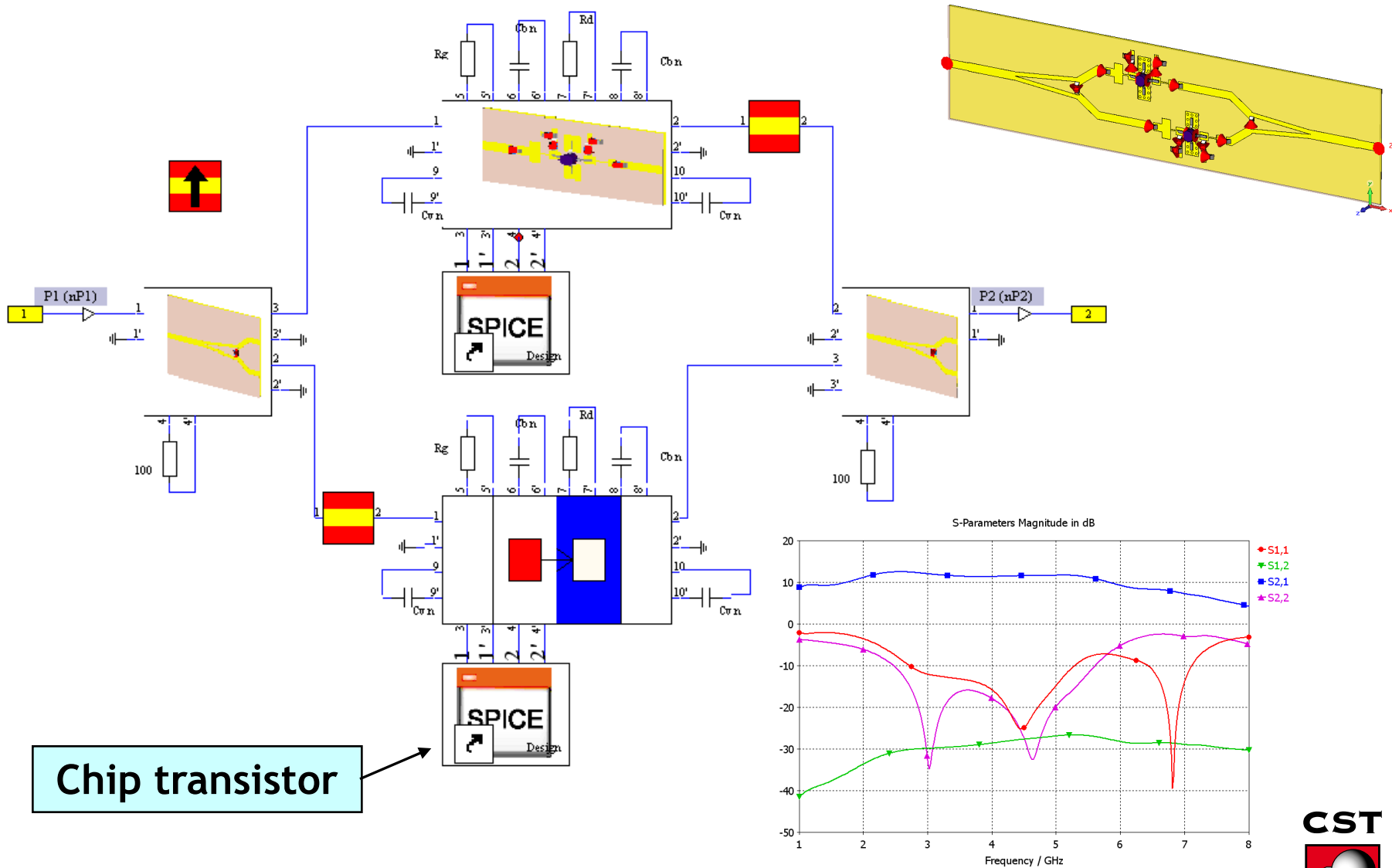

Example 5: UWB Balanced Amplifier II.

(Transient Co-simulation)

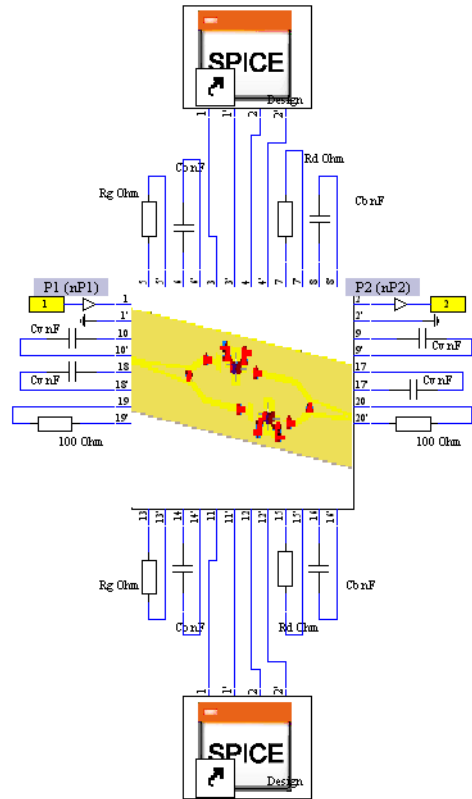
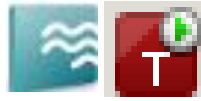

DS canvas:

20 ports

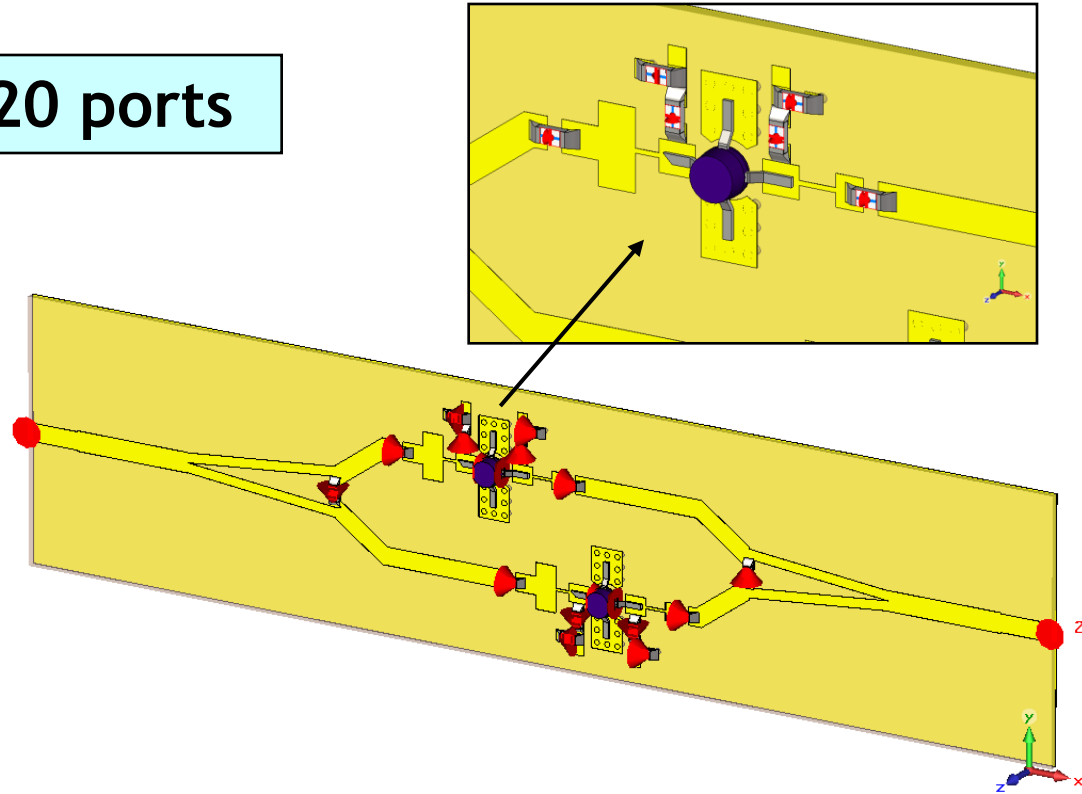

MWS model

- circuit elements
- transient task with „MWS Co-simulation“
- probes

Example 5: UWB Balanced Amplifier II. (Transient Co-simulation)

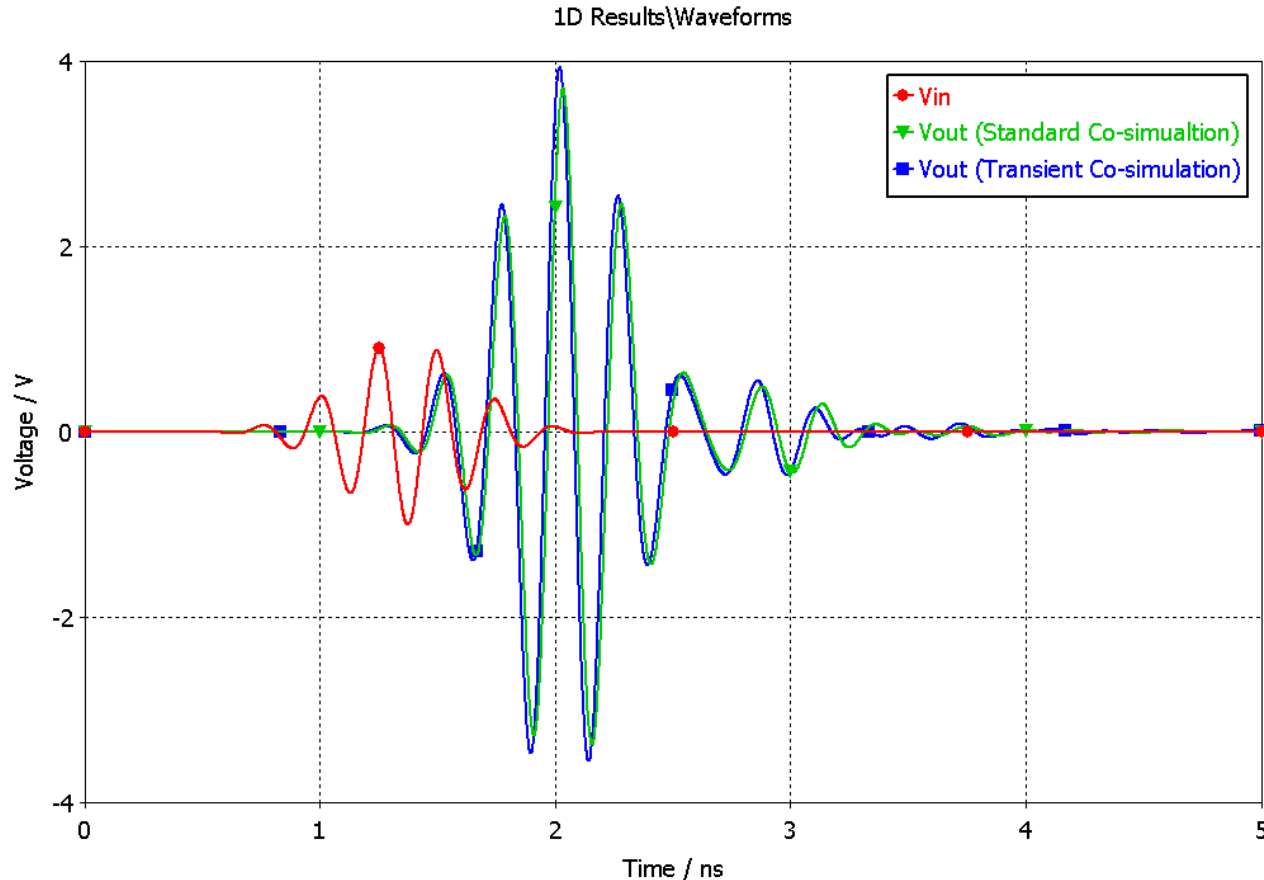
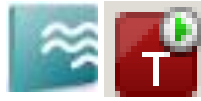

Transient Co-Simulation is approx. **5x** faster than the standard Co-Simulation using S-parameter matrix and spice model extraction.

Conclusions

Standard Co-simulation

- Fast optimization at the circuit simulator level
- Complete S-matrix is needed
- Spice model extraction is needed for transient task
- Suitable for steady-state analysis

True Transient Co-simulation

- Optimization only thru 3D EM simulation
- Fast 3D simulation of complex structure having high number of lumped components/ports
- No need of spice model
- Suitable for pulse-regime analysis
- Investigation of the whole circuit including box influence.

Thank you for your attention...